



### 11.1 SCOPE.

**11.1.1 Purpose.** This section establishes the engineering drawing requirements for specifying the marking of part identification, serialization and other information on hardware per ASME Y14.100 and as applicable Appendix B.

**11.1.2 Items Excluded From Identification Marking In This Section.** Certain items are excluded from the provisions of this section because of their peculiar nature and are covered by additional specifications and standards relevant to their requirements. General categories for these items are listed below. Refer to MIL-STD-130 for their applicable specifications and standards for methods of identification.

- a. Clothing
- b. Batteries (Wet and Dry)
- c. Electrical and Electronic Items
- d. Raw Material
- e. Rubber Products
- f. Ammunition
- g. Color Marking
- h. Electron Tubes
- i. Programmed Tapes and Cards
- j. Microcircuits
- k. etc. misc. metals. See MIL-STD-130

**11.1.3 Application And Tailoring.** The contract, purchase order, or work order shall be reviewed for identification requirements to determine if "tailoring" can be expressed on the contract to ensure that only the minimum essentials need be used to identify the item.

### 11.2 APPLICABLE DOCUMENTS. Note: DoD Policy Memo 05-3 "Elimination of Waivers to Cite Military Specifications and Standards in Solicitation and Contracts" has eliminated the need for waivers to use MIL-SPECS and MIL-STDS on DoD contracts. (See PREFACE 1, Section 2)

A-A-208	Ink, Marking, Stencil, Opaque (Porous and Non-Porous Surfaces)
TT-L-50	Lacquer, Nitrocellulose, Acrylic and Acrylic-Butyrate Aerosol (In Pressurized Dispensers) (CNCLD: Supsd by: ASTM D 740)
*MIL-STD-13231	Marking of Electronic Items
MIL-STD-100	Engineering Drawing Practices (Use in conjunction with ASME Y14.100) (CNCLD Supsd by: ASME Y14.100 & Appendices, ASME Y14.24, Y14.34M & Y14.35M)
MIL-STD-129	Marking for Shipment and Storage
MIL-STD-130	Identification Marking of U.S. Military Property
MIL-STD-973	Configuration Management
MIL-STD-1189	Standard Department of Defense Bar Code Symbology (CNCLD)
*MIL-STD-1285	Marking of Electrical and Electronic Parts
MIL-STD-1686	Electrostatic Discharge Control Program for Protection of Electrical & Electronic Parts, Assemblies and Equipment (Excluding Electrically Initiated Explosive Devices)
MIL-HDBK-57	Listing of Fastener Manufacturer's Identification Symbols
MIL-HDBK-263	Electrostatic Discharge Control Handbook for Protection of Electrical and Electronic Parts, Assemblies and Equipment (Excluding Electrically Initiated Explosives Devices)
H4/H8 Sect A	Commercial and Government Entity (CAGE) (Name to Code)



---

H4/H8 Sect B	Commercial and Government Entity (CAGE) (Code to Name)
H6	Federal Item Name Directory (FIND)
AIM BC1	Uniform Symbology Specification Code 39
ANSI X3.17	Character Set for Optical Character Recognition (OCR-A) (INACTIVE)
EIA-471	Symbol and Label for Electrostatic Sensitive Devices
ASME Y14.100	Engineering Drawing Practices
ASTM D 740	Methyl Ethyl Keytone
SAE AS478	Identification Marking Methods

\* Military items covered by these documents are excluded from the provisions of MIL-STD-130 unless otherwise specified in the detail specification, standard or contract.

### **11.3 DEFINITIONS.** (Alphabetically Listed).

**11.3.1 Bar Code.** An array of rectangular bars and spaces in a predetermined pattern.

**11.3.2 Commercial and Government Entity (CAGE) Code.** A five-character code listed in Cataloging Handbook H4/H8 which is assigned to commercial and Government activities that manufacture or develop items, or provide services or supplies for the government. When used with a drawing number or Part or Identifying Number (PIN), the CAGE code designates the design activity from whose series the drawing or PIN is assigned. The CAGE code was previously called manufacturer's code, code identification number, or Federal Supply Code for Manufacturers (FSCM). (Ref: ASME Y14.100 and as applicable Appendix B.)

**11.3.3 Commercial Item.** A product, material, component, sub-system, or system sold or traded to the general public in the course of normal business operations at price based on established catalog or market prices. (Ref: MIL-DTL-31000) Also referred to as commercial off-the-shelf (COTS or OTS) products, or commercial products.

**11.3.4 Configuration Element Identifier (CEI).** The number assigned to identify a configuration element, an item subject to configuration management such as a Contract or Configuration End Item (CEI).

**11.3.5 Configuration Item (CI).** A configuration item is an accumulation of hardware or software that satisfies an end use function and is designated by the government for separate configuration management.

**11.3.6 Configuration Item Identification Number (CII Number).** The alpha-numeric number assigned to identify a configuration item. When assigned, it is the unchanging base number to which serial numbers are assigned. (Ref: MIL-STD-973)

**11.3.7 Contractor.** Any individual, company, partnership, association, or corporation holding a contract or letter of intent to supply items for the Government, commercial or a nonprofit organization.

**11.3.8 Design Activity.** The activity having responsibility for the design of an item. It may be a Government, Commercial, or a nonprofit organization. (Ref: ASME Y14.100 and as applicable Appendix B.)

**11.3.8.1 Current Design Activity (CDA).** An activity (Government or contractor) currently having responsibility for the design of an item, and the preparation and maintenance of drawings and associated documents. Current design activity could be the original design activity or new activity when that responsibility is transferred from another Government or contractor design activity. (Ref: ASME Y14.100 and as applicable Appendix B.)



**11.3.8.2 Design Activity Identification.** The design activity's CAGE or NSCM.

**11.3.8.3 Original Design Activity (ODA).** An activity (Government or contractor) having had the responsibility originally for the design of an item and whose drawing number and CAGE code is shown in the title block of drawings and associated documents. (Ref: ASME Y14.100 and as applicable Appendix B.)

**11.3.9 End Item.** A part, assembly, unit, set or system that is the finished product or the prime level of assembly.

**11.3.10 Item.** A non-specific term used to denote any unit or product including materials, parts, assemblies, equipment, accessories and computer software.

**11.3.11 Item Identification.** The combination of the PIN and the original design activity CAGE code. (NOTE: Not applicable to specification controlled items.)

**11.3.12 Manufacturer.** An individual, firm, company, or corporation engaged in the fabrication of finished or semi-finished products and whose name, registered trademark listed in MIL-HDBK-57 or code identification is established in Cataloging Handbooks H4/H8 "Commercial And Government Entity" (CAGE) Code or as otherwise specified who;

- a. Controls the production of an item, or
- b. produces an item from crude or fabricated materials, or
- c. assembles materials or components, with or without modification, into more complex items (Ref: ASME Y14.100 and as applicable Appendix B.)

**11.3.13 Manufacturer's Identification.** The actual manufacturer's name, CAGE or NSCM that identifies the place of manufacture.

**11.3.14 National Stock Number (NSN).** A number assigned to each item of supply, which is purchased, stocked, or distributed within the Federal Government.

**11.3.15 NATO Supply Code For Manufacturers (NSCM).** The five-position alpha numeric code that is assigned to an organizational entity, located in a country other than the United States or Canada, that maintains design control or is a source of supply for items acquired by agencies of the Federal Government, NATO member nations, and other participating friendly Governments.

**11.3.16 Part Or Identifying Number (PIN).** The identifier assigned by the responsible design activity or by the controlling nationally recognized standard which uniquely identifies (relative to that design activity) a specific item. The PIN generally includes the controlling drawing or document number and optional suffix. The PIN does not include the drawing revision identifier, drawing size, or CAGE code. The term "part or Identifying Number" replaces the terms "part Number" and "bulk material identification number".

NOTES:

1. When a PIN is assigned to an item of production, it shall be or shall include the design activity drawing number and shall be used as a part of the identifying number. The identifying number for parts, sub-assemblies or assemblies, units, groups, and sets shall contain the design activity CAGE or NSCM as a prefix. (see Cataloging Handbook H4 / H8.)
2. When the acquiring document cites a vendor item control drawing number for the item being acquired, the manufacturer's (vendor's) PIN prefixed with the manufacturer's CAGE or NSCM, shall be used as the identifying number in lieu of the vendor item control drawing number when marking of items is required by the acquiring document.



**11.3.17 Permanent Marking.** A method of identification which will remain legible during the normal service life of an item.

**11.3.18 Acquisition Instrument Identification Number.** The Government procuring activity's contract or purchase order number. When an order shows both a contract number and a purchase order number, the Acquisition Instrument Identification Number shall be as specified by the procuring activity.

**11.3.19 Registration Number.** The number assigned by the Government to an individual unit of a group of items. The number registers Government ownership, responsibility, and accountability (e.g., vehicle registration numbers).

**11.3.20 Repairable.** Having the capability of being repaired.

**11.3.21 Sensitive Electronic Devices (SED).** Electronic parts having highly sensitive characteristics (e.g., thin-layered internal composition) and delicate, miniaturized construction which are susceptible to damage or degradation, in various degrees, from environmental field forces (electrostatic, electromagnetic, magnetic, or radioactive) as well as more mundane sources such as corrosion, shock, vibration, foreign particle intrusion, biological contamination, thermal stress and thermal shock. This susceptibility also extends to the standard electronic modules, printed circuit boards, printed wiring boards, and circuit card assemblies containing one or more of these sensitive electronic parts.

**11.3.22 Serial Number.** An alpha and/or numeric code assigned to an item to differentiate that item from any other item of the same part or identification number. The identifier "SERNO" may be used to avoid confusion with other identifiers and when marking space allows. (Ref: MIL-STD-973)

**11.3.23 Set.** A unit or units and necessary assemblies and parts connected or associated together to perform an operational function. Also used to denote a collection of parts, such as "tool set".

**11.3.24 Special Characteristics.** The pertinent rating, operating characteristics, and other information necessary to describe the item.

**11.3.25 Specification Data.** Information such as specification number, type, grade, class, or other identifying data.

**11.3.26 Stock Number.** The National/NATO Stock Number (NSN), without prefix or suffix, as specified by the procuring activity.

**11.3.27 System.** A combination of parts, assemblies and sets joined together to perform an operational function.

**11.3.28 Temporary Marking.** A method of in-process identification which can be removed without defacing or damaging an item.

**11.3.29 Unit.** An assembly or any combination of parts, subassemblies and assemblies mounted together normally capable of independent operation in a variety of situations.

**11.3.30 U. S.** The abbreviation used to denote Government ownership with DoD jurisdiction.

**11.3.31 Vendor Item Control Item.** Items depicted on vendor item control item drawings in accordance with definitions and requirements contained in SECTION 4 herein per ASME Y14.100 and Appendix D.

**11.3.32 Warranty.** A warranty is the contractual agreement between the Government and the contractor relative to the nature, usefulness, or condition of the item(s) furnished under the contract. Warranty duration is expressed in terms of hours, days, months, number of operations, etc. Warranty markings give notice to a user whether the item(s) is subject to the warrant provisions.



## **1.4 GENERAL REQUIREMENTS.**

**11.4.1 Method Of Marking.** The design activity shall specify the actual method(s) on the drawing of a part, assembly, unit, set or other item of supply shall specify markings consistent with the requirements of SAE AS478 or ASME Y14.100 Appendix D including MIL-STD-130 as applicable. Marking shall be clear on such details as method of application (i.e. stamp, stencil), materials (i.e. ink, lacquer) and location. Use an acceptable method that is not detrimental to the hardware or will not adversely affect its life, utility or function.

**11.4.2 Unmarkable Items.** Materials (e.g., powders, liquids, etc.) which by their physical nature cannot be marked, will be specified as part of the packaging requirements consistent with MIL-STD-129. Requirements for marking and references to MIL-STD-129 shall not be specified on the item drawing.

**11.4.3 Temporary Markings.** Part identification for components of subassemblies and assemblies which are not subject to disassembly or repair may be specified by temporary markings.

**11.4.4 Marking Items Without Sufficient Surface.** Drawings of parts which do not have a suitable surface or sufficient space for marking will specify tagging or marking the container.

**11.4.5 Restrictions Of Reidentified Items.** Government and Industry standard parts or vendor items are not reidentified except as specified in the requirements for altered or selected parts.

### **11.4.6 Marking of Vendor Item Controlled Items.**

**11.4.6.1 Source Control Items.** When marking source control items, they shall be marked with the design activity CAGE or NSCM, the source control notation (SOCN), and the source control PIN; (example: 12345 SOCN 789034).

When specified by the acquiring activity, the item manufacturer shall be identified as described in PARAGRAPH 11.9.4. The vendor's identification and identifying number need not be removed.

**11.4.6.2 Vendor Item Control Items.** When marking vendor item control items, they shall be marked with the manufacturer's (vendor's) PIN preceded by the manufacturer's CAGE or NSCM number. The Vendor Item Control Drawing (VICD) number shall not be used to physically reidentify the item from the original design activity part number. In the event that a vendor item control item is a commercial off-the-shelf (COTS) item, see PARAGRAPH 11.3.3 and refer to PARAGRAPH 11.4.16b (1).

**11.4.7 Non-Hazardous Marking Materials.** Marking materials creating hazardous conditions shall not be used.

**11.4.8 Visibility Of Marking.** Marking, whenever practicable, shall be located to allow visibility during use. The location of the marking may be specified on the drawing or other document by the design activity.

**11.4.9 Life Expectancy Of Marking.** Markings shall be as permanent as the normal life expectancy of the item. Identification tag marking, when used, shall be permanent to the extent required for utilization of the item.

**11.4.10 Abbreviation Of Markings.** Abbreviated information, to limit costs or for other considerations, shall include only the most essential information as specified by the procuring activity shall be such as the CAGE and part number.

**11.4.11 Information Not Required.** Special characteristics may be omitted from the identification plate, if the pertinent information is on a manufacturer's data plate on the item, provided the manufacturer's plate meets the permanency and legibility requirements of the method of marking selected.

**11.4.12 U.S. Marking to indicate Government Ownership.** The designation "U.S." shall be marked only when specified in the detail (commodity) specification, or in the acquisition document.

**11.4.13 Font Of Markings.** Letters shall be clear and concise type faces such as "Gothic" or "Futura" and in capitals. The numbers shall be Arabic except when Roman numerals are used for type designations in Military specifications and standards.



**11.4.14 Legibility.** Identification marking shall be legible and make full use of the available marking area. Characters shall be block form capital letters and Arabic numerals without serifs, such as "Gothic or "Futura". Lower case letters may be used when required for metric unit symbols. Other characters shall be of similar appearance. Condensed letters and smeared letters shall be cause for rejection. Templates for the electrochemical process may be produced by a conventional typewriter provided legibility is maintained. Processes performed after marking which may reduce legibility (such as vapor or grit blasting, tumbling, etching, etc.) shall be controlled to prevent loss of legibility. Normally all characters shall be legible without magnification. However, where space or surface condition limits the size of characters that may be used, legibility with 3X magnification maximum is permissible when authorized.

**11.4.15 Bar Coding.** Machine readable (Bar coding) marking is not applicable unless otherwise required in the contract or purchase order. When required, the acquiring activity must specify the type to be used. Bar coding determination is governed by the following criteria.

- a. Any item (part), except those specified in PARAGRAPH 11.4.15b (1), (2) and (3), which is serialized, repairable, a Configuration End Item (CEI), unique, or having a high dollar value as defined by the acquiring activity shall have the following information bar code:
  - (1) Serial number, if applicable.
  - (2) NSN NOTE: If the NSN is not available, the manufacture's PIN or item identification shall be applied by bar code or other machine readable system.
  - (3) Applicable CAGE or NSCM code.
- b. Other item(s) (Part) may or may not be bar coded unless bar coding is expressly specified in the contract or purchase order. Items shall be individually marked with the applicable design activity's CAGE or NSCM, a dash (or slant), and PIN. See PARAGRAPH 11.9. Exceptions are as follows:
  - (1) Commercial Off The Shelf (OTS) items marked with commercial identification (firm name, logo, PIN, etc.). These be exempt from additional marking requirements unless otherwise specified by contract or purchase order, This exemption extends to commercial OTS items identified on Vendor Item Control Drawings (VICD).
  - (2) Parts within an assembly which is not subject to removal, replacement or repair.
  - (3) When parts are deemed to small for application of complete marking of PARAGRAPH 11.4.15b. A logo shall be acceptable for the CAGE or NSCM code.

**11.5 MARKINGS.**

**11.5.1 "Method Of Marking" Symbols.** Standard symbols established by SAE AS478, "Identification Marking Methods," denote the method and general location for the marking

**11.5.1.1 General.** This symbol,  or a local note, indicates general location for marking.

**11.5.1.2 Pad.** This symbol,  or a local note, indicates pad location for marking.

**11.5.1.3 Integral.** This symbol,  or a local note, indicates location for integral marking (Cast, Forged, or Molded).

**11.5.1.4 Specific.** This symbol,  or a local note, indicates a specified area within which markings must be confined.



**11.5.2 Marking On Moving Surfaces.** Permanent marking is not recommended on contacting surfaces, nor on surfaces which are in motion with respect to the mating surface during the operation of the items. However, when permanent marking must be placed on such surfaces, all raised metal and burrs shall be removed in accordance with the requirements given on the drawing.

**11.5.3 Marking On Processed Surfaces.** Permanent marking shall not be applied on surfaces which have been chemically processed, painted, or plated unless the marking will be legible and the minimum requirements of the surface treatment process maintained or restored.

**11.5.4 Marking Height Control.** The height of permanent marking characters is established by the applicable standard and is not specified on the drawing, except when necessary to satisfy design or contractual requirements. See PARAGRAPHS 11.6.1. and 11.6.1.1.

**11.5.5 Visibility Of Marking After Installation.** Whenever practicable, the permanent marking of a part or assembly is located to be visible after installation.

**11.5.6 Restrictive Use Of Item Numbers.** Item numbers, used for reference purposes on the drawing, shall not be used as part identification numbers.

## **11.6 MARKING METHODS.**

**11.6.1 Permanent Marking.** Permanent marking shall not affect the function or service-ability of the item. Permanent marking for the general categories of items shall normally be between .060 and .160 inch [1.5 and 4 mm] in height. In special cases when governed by size or configuration, .016 inch [0.4mm] minimum or .250 inch [6.35 mm] maximum height is permissible, or as otherwise specified in this standard or on the drawing.

**11.6.1.1 Integral.** Characters are produced by casting, forging, or molding into or onto the item. When integral marking is used, the height should not exceed .500 inch [12.7 mm] nominal character size.

**11.6.1.2 Metal Stamp.** Characters are produced by forcible displacement of material.

- a. **Hammer.** Characters are produced individually or in groups by impact force applied mechanically or by hand.
- b. **Press.** Characters are produced individually or in groups with a controlled force applied without impact.
- c. **Roll.** Characters are produced by a rotating motion of either the item or the tool, or both when in contact with each other under a controlled force.
- d. **Vibro Peen Manual.** Characters are produced by a hand-guided, rapidly vibrating tool having a pointed tip making indentations on the item to produce the characters.
- e. **Vibro Peen Controlled.** Characters are produced by a mechanically guided rapidly vibrating tool.
- f. **Dot-Peening.** Characters are formed by a series of indentations or dots wherewith the spacing between dots and characters are controlled by a microprocessor.

**11.6.1.3 Engrave.** Characters are produced by a rotating cutter or grinder.

- g. **Manual.** Characters are produced by a hand-guided, rotating cutter or grinder.
- h. **Controlled.** Characters are by a mechanically or electromechanically guided, rotating cutter or grinder.



**11.6.1.4 Electric Arc Scribe.** Characters are produced by the action of an electric arc between the surface and an electrode which acts as the scribe.

- a. **Manual.** Characters are produced by a hand-guided scribe.
- b. **Controlled.** Characters are produced by a mechanically guided scribe.

**11.6.1.5 Scribe.** Characters are produced by a cutting or scratching action.

- a. **Manual.** Characters are produced by a hand guided-tool.
- b. **Controlled.** Characters are produced by a mechanically or electromechanically guided, radius tipped, conical tool.

**11.6.1.6 Acid Etch.** Characters are produced by the use of a strong acid. Application of the acid may be by any means, but care shall be exercised to prevent acid or fumes from spreading to the surrounding area. The surface to be etched shall be clean. After etching, the acid shall be neutralized and corrosion preventative treatment applied.

**11.6.1.7 Electrochemical Process.** Characters are produced by use of a controlled pH electrolytic solution to facilitate electrolysis which is confined to the area of the characters by a stencil. After marking, the electrolyte shall be neutralized and corrosion preventive treatment applied.

- a. **Electrochemical Etch.** Characters are produced by removing material with an electrolytic process. Characters shall be dark or of a sufficient contrast to assure good visibility.
- b. **Electrochemical Deposit.** Characters are produced by adding material with an electrolytic process employing DC reverse polarity. Deposit marking does not have the durability or permanency of etch or other material displacement methods and should not be specified where the loss of identification under normal service conditions is objectionable. **INACTIVE FOR NEW DESIGN:** There is no known source for marking equipment.
- c. **AC Etch.** Characters are produced by removing material with an electrolytic process employing AC. When authorized, material may be removed by the use of DC straight polarity with the part positive.
- d. **AC Etch DC Deposit.** Characters are produced by removing material by the AC Etch method followed by the addition of material by applying DC reverse polarity.

**11.6.1.8 Blast.** Characters are produced by the impingement of an abrasive substance confined to the area of the characters by a stencil.

**11.6.1.9 Brand.** Characters are produced by burning or displacing material with a heated tool.

- a. **Hot Press.** Characters are produced by controlled impression of colored foil with a heated die.

**11.6.1.10 Ceramic.** Characters are produced by a contrasting ceramic coating applied by any means prior to the initial firing.

**11.6.1.11 Decalcomania.** A pigmented film bearing the required identification applied by transfer from a suitable backing to the item. When dried, it is recommended that the film be coated with a clear lacquer per ASTM D 740 (Supersedes TT-L-50); the marking shall be legible after coating.

**11.6.1.12 Plate.** A data or name plate bearing the required identification marking is securely affixed to the item.

**11.6.1.13 Band.** A band bearing the required identification marking is permanently attached to the item.





**11.6.1.14 Pressure Sensitive Label.** An environment-resisting label bearing the required identification, backed with pressure sensitive adhesive, is applied to the item.

**11.6.1.15 Laser.** Characters are produced by displacing material with a laser beam. Depth is controlled by varying the pulse rate of the beam, the speed of advance, the focus, and the power.

- a. **DOT Matrix Mode.** Characters are formed by a series of dot-like depressions in the material.
- b. **Engrave Mode.** Characters are formed by a continuous depression in the material.

**11.6.1.16 Plastic Laminate.** On laid-up plastic parts, the identification marking may be applied with ink or paint and then covered by a layer of the same resin used in underlying laminate. Alternatively, the identification may be marked on a separate piece of fabric or paper which is bonded to the substrate with resin and then covered with resin. The ink or paint and the fabric or paper shall withstand the cure cycle, if applicable. The ink or paint and the resin shall have good adhesion to the composite substrate, shall be compatible with each other, shall withstand the cure cycle if applicable, and be compatible with the service environment of the part. The marking shall be legible through the cured resin.

**11.6.2 Temporary Marking.** Temporary marking shall not adversely affect the function or serviceability of the item. On items subject to intense heat, any temporary marking method which leaves a heavy carbon deposit or sufficient detrimental residue such as cadmium, copper, zinc, lead, etc., should be avoided or, when used, should be removed before subjection to intense heat.

**11.6.2.1 Ink.** Characters are produced by applying an ink by any means which does not injure the surface. When a final marking is applied to a painted surface by ink stamping, it is recommended that the marking be coated with a clear lacquer per ASTM M 740, or equivalent. The marking shall be legible after coating.

**11.6.2.2 Dye.** Characters are produced by applying a dye by any means which does not injure the surface. It is recommended that a coating of clear lacquer per ASTM D 740, or equivalent, be applied over the marking; the marking shall be legible after coating.

**11.6.2.3 Paint.** Characters are produced by painting, with or without a stencil. It is recommended that a coating of clear lacquer per ASTM D 740 (Supersedes TT-L-50) or equivalent, be applied over the marking; the marking shall be legible after coating.

**11.6.2.3.1 Silk-Screen.** Characters are produced by forcing paint through a fabric stencil. It is recommended that a coating of clear lacquer per ASTM D 740, or equivalent, be applied over the marking; the marking shall be legible after coating.

**11.6.2.4 Chalk.** Characters are produced by marking with chalk.

**11.6.2.5 Crayon.** Characters are produced by marking with a wax crayon.

**11.6.2.6 Tag.** A tag bearing the required identification marking shall be permanently attached to the item, or to a bag containing the item. The tags shall be separately defined as a component by applicable specification, standard or drawing. The requirements for permanently attaching the tag shall be specified on an assembly drawing. The markings and methods of marking the tags may be specified on either the assembly drawing or tag component drawing. The means of attachment and location shall be such that no damage shall be done to the item.

**11.6.2.7 Band Or Tape.** A band or tape bearing the required identification marking is temporarily attached to the item.

**11.6.3 Package Marking.** The package bears the identification of the item which is too small or otherwise impractical to be marked.



## 11.7 DRAWING APPLICATION.

**11.7.1 Alternate Choice Of Marking.** When design conditions permit, one or more alternative methods and recommended depths of marking should be specified. See TABLE 11-3.

**11.7.2 Marking Process Omitted.** The marking process name is not specified on the drawing (electroetch, etc.) The word "etch" is sufficient).

**11.7.3 Dual Marking Restriction.** Hardware cannot be identified with subsequent part numbers. That is, a detail part cannot be marked with the assembly part number.

**11.7.4 Single Marking Per Item In Its Final Form.** Parts are marked with one part number only.

**11.7.4.1 In-Process Marking.** In-process identification for parts is not normally specified on the engineering drawing; when necessary, it is specified by a temporary marking process that will not affect the surface to which the marking is applied and can be readily removed.

**11.7.4.2 Multiple Markings On One Item.** Parts containing more than one part number will distinguish between the numbers. For example, an assembly containing a machined casting could have three part numbers: a casting part number, a machined part number and an assembly part number. The casting part number would have the prefix "CSTG" and the assembly part number would have the prefix "ASSY" to distinguish between the numbers.

**11.7.5 Specifically Located Markings.** Permanent part identification markings are normally specified on the field of drawing, but may also be specified in a general note with a flag symbol referencing the location. The same note is used for either the field of drawing or in the general notes. The area within which the markings must be confined is indicated by a phantom block, but is not dimensioned except when design conditions require such control.

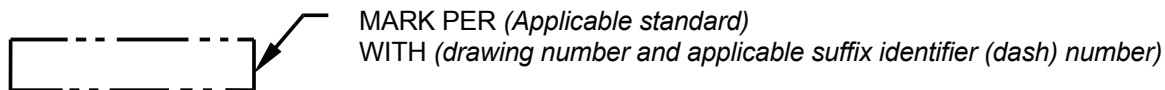

**11.7.6 Serial Number Assignment.** When hardware is required to be permanently marked with a serial number, the requirement is specified by the addition of "AND ASSIGNED SERIAL NUMBER" to the marking note.

Example:

MARK PER (*applicable standard*) WITH (*drawing number*) AND (*applicable suffix identifier (dash) number*) AND (*assigned serial number*).

**11.7.6.1 Serial Number Carryover.** When an inseparable assembly contains a critical or major component that requires carryover serialization, the notation "AND SERIAL NUMBER OF (*applicable part number*)" is added to the marking note.

Example:

MARK PER (*applicable standard*) WITH (*drawing number and applicable suffix identifier (dash) number*) AND SERIAL NUMBER OF (*applicable part number*).

**11.7.7 Markings For Additional Requirements.** Markings for additional requirements, such as quality control results, foundry trademark, forge shop symbol, etc., are shown in Section 16 and 17 for casting, forging and their integral, separate or combined machining drawings.



**11.7.8 Matched Set Marking.** Matched sets or parts require markings to identify each component separately and as a part of the matched set. The complete matched set is assigned an assembly number and the detail part identification is correlated to the assembly part identification and serial number. See SECTION 7, PARAGRAPH 7.9.6. The matched set is identified on the next assembly by the matched set assembly number. The part identification for each of the components comprising the matched set is specified by the following note:

Example: MARK IN ACCORDANCE WITH (*applicable standard*) WITH (*drawing number and applicable detail suffix identifier (dash) number part of assembly*) AND ASSIGNED SERIAL NUMBER.

**11.7.9 Altered Or Selected Part Marking.** Altered and/or selected parts are reidentified with a company part number and the original identifying number is obliterated or removed, if this can be done without damage to the part. The requirement for the obliteration or removal is specified in the marking note, but the specific method or process to be used is left to the discretion of the fabrication group.

Example: REMOVE ORIGINAL PART NUMBER WITHOUT DAMAGE TO HARDWARE. MARK IN ACCORDANCE WITH (*applicable standard*) WITH (*applicable drawing number and applicable suffix identifier (dash) number*).

**11.7.10 Location Of Temporary Marking Note.** Temporary markings are normally specified in a general note, but may be specified on the field of drawing when necessary for clarity.

Example: TEMPORARY MARKING PER (*applicable specification*) WITH (*applicable drawing number and applicable suffix identifier (dash) number*).

**11.8 IDENTIFICATION PLATES, DECALCOMANIAS, LABELS AND OTHER MARKING DEVICES.**

**11.8.1 Use Of Identification Plates.** The use of identification or information plates, decalcomanias, labels and other marking devices on assemblies, units, sets, systems or other end items is established by company policy and/or contractual requirements. It is the designer's responsibility to determine and specify the requirements for his project. The plates shall be separately defined as a component by applicable specification, standard or drawing.

**11.8.2 Identification Plate Callout.** The identification plate or other marking device used is specified in the parts list and on the field of drawing. Attaching hardware or other requirements are also specified when necessary.

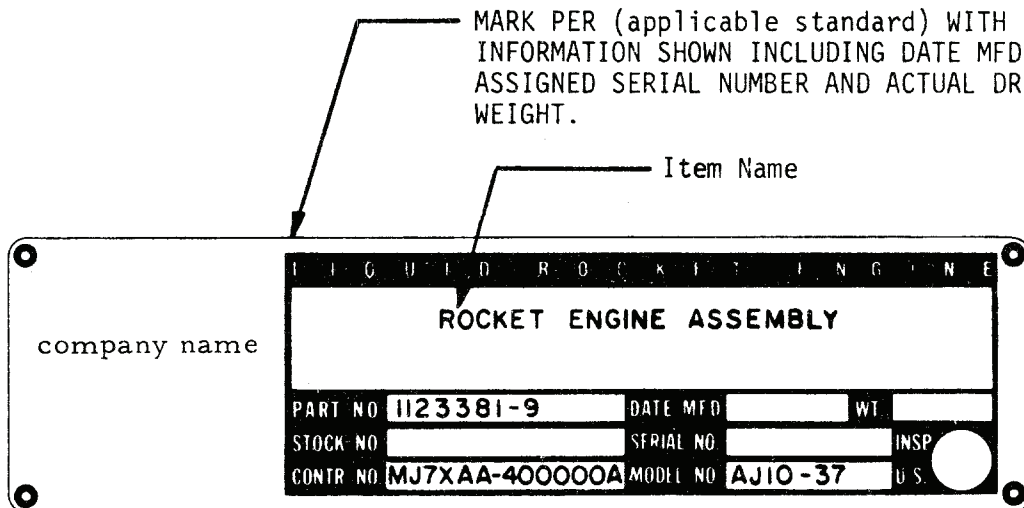

IDENTIFICATION PLATE EXAMPLE  
FIGURE 11-1



**11.8.3 Markings Applied To Identification Plate.** When markings are to be applied to the marking device, a note or detail and note, will specify the markings and the methods of marking the plates on either the assembly drawing or plate component drawing. See FIGURE 11-1.

**11.8.3.1 Variable Marking Information.** When applicable (i.e., required by detail specification or in the acquisition document).

- a. Specification data (type, grade, class, or other identifying data).
- b. Date of acceptance.
- c. Date of manufacture.
- d. Registration number (e.g. vehicle registration number for government ownership).
- e. Weight and volume.
- f. Lot number.
- g. Technical manual number.
- h. Matched set identification.
- i. Additional data identified by contract.

**11.8.3.2 Bar Code Marking For Identification Plate and Other Marking Devices.** Bar coding is not applicable unless otherwise specified in the contract or purchase order. When required, the identification plate, or other marking device, shall include as minimal the bar coding as required in PARAGRAPH 11.4.15a and as applicable PARAGRAPH 11.4.15b. See FIGURE 11-2.

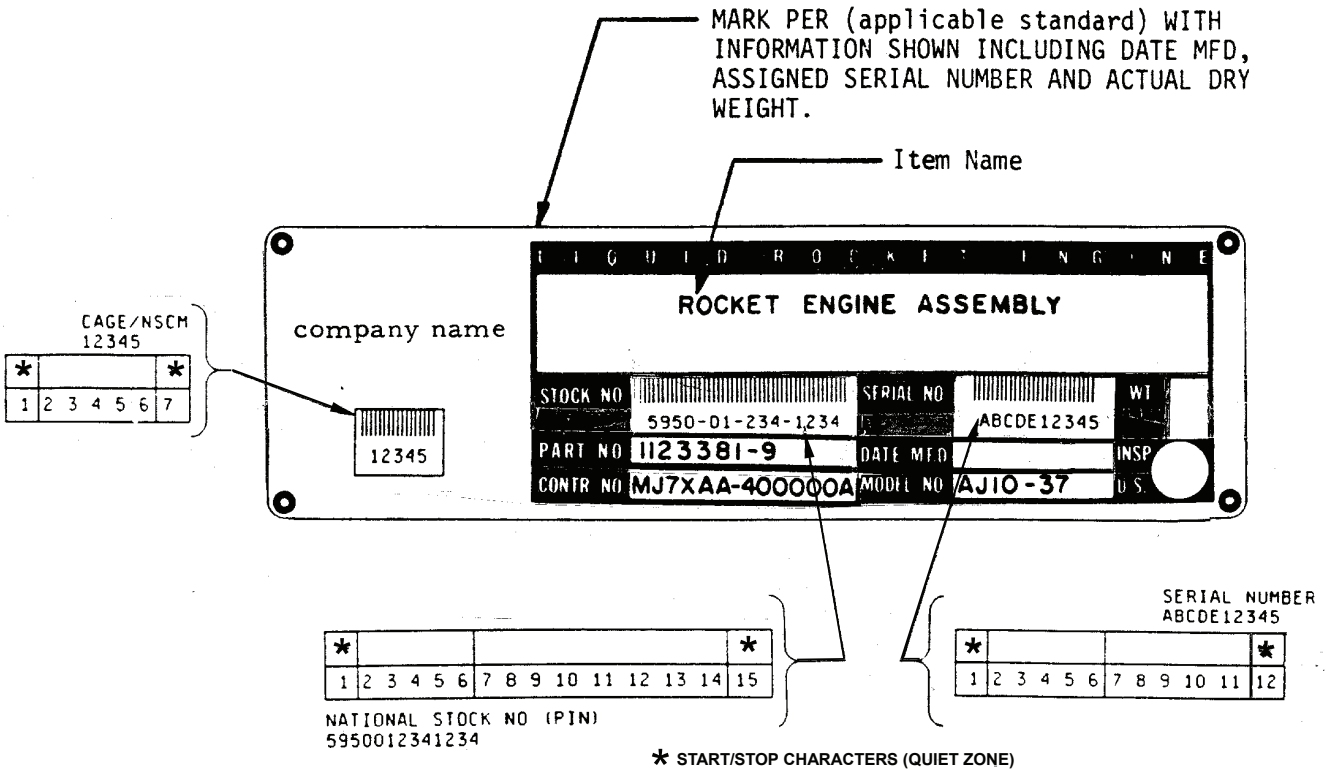

EXAMPLE OF BAR CODE MARKING FOR IDENTIFICATION PLATE OR OTHER MARKING DEVICES  
FIGURE 11-2



**11.8.3.3 Bar Code Symbology Size Requirements.** Standard Industry Bar Code Symbology (SDS) is referred to as "The 3 of 9 bar code" with a density of 9.4 Characters Per Inch (CPI) and a Human-Readable Interpretation (HRI) applied preferably below the bar code symbol. The 3 of 9 bar code shall be used for all applications unless otherwise specified. See AIM BC-1 for other selected CPI densities. FIGURE 11-3 displays the SDS message "ABC" or Arabic numerals, which ever is the case, as listed in TABLE I of MIL-STD-1189 (CNCLD).

<b>NOW</b> AIM BC-1 -1995	<b>WAS</b> MIL-STD-1189B (CANCELED 18 JUNE 1997)
CODE 39 (ALSO CALLED CODE 3 OF 9) USERS should evaluate this specification before citing it as a replacement document	THE 3 OF 9 BAR CODE With a density of 9.4 Characters Per Inch (CPI)

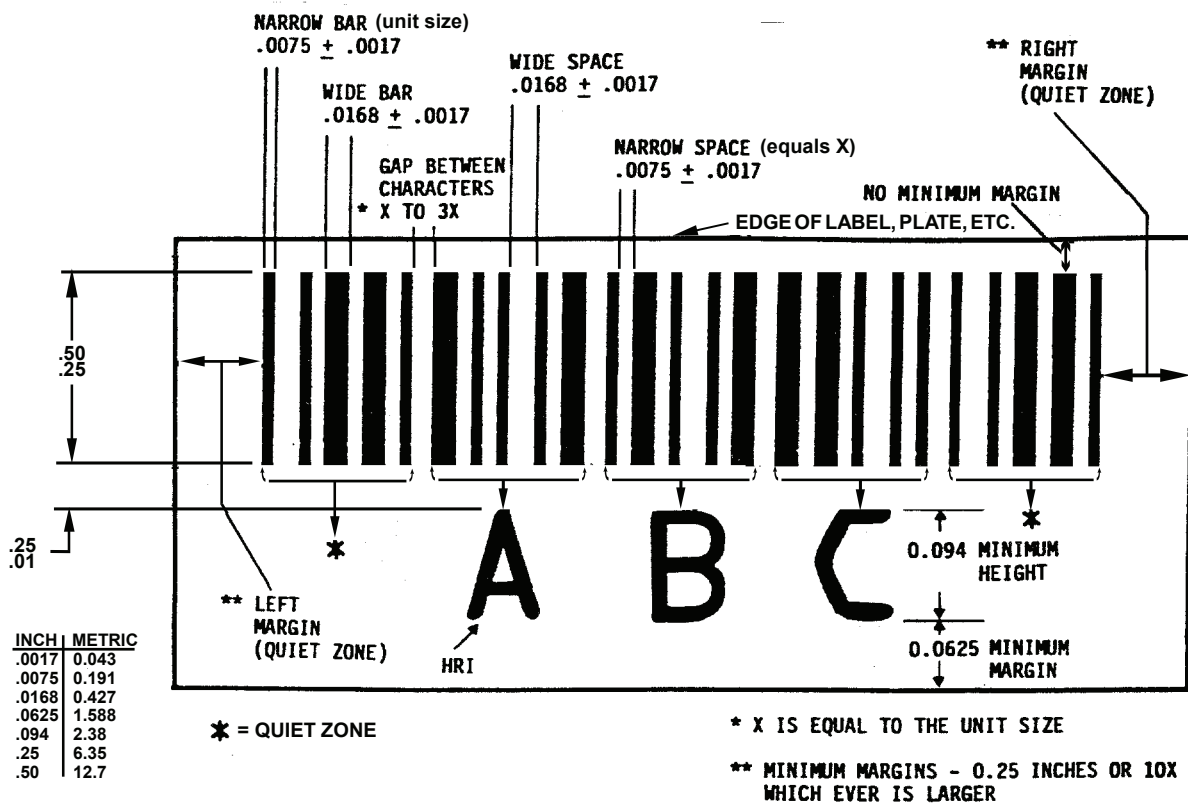

3 OF 9 BAR CODE SYMBOLOGY SIZE REQUIREMENTS FOR HIGH DENSITY BAR CODE 9.4 CHARACTERS PER INCH (CPI) (SCALE ENLARGED FOR CLARITY)



Example: A Bar Code Symbol (SDS) for 3 of 9 with a density of 9.4 Characters Per Inch (CPI) with a Human-Readable Interpretation (HRI) applied below. This is an actual full size sample used by Federal Express for tracking packages during shipment and proof of delivery.

FIGURE 11-3



**11.8.4 Attachment Of Metal Plates To The Item.** The requirements for permanently attaching the plates shall be specified on the assembly drawing.

**11.8.5 Life Expectancy Of Marking.** The marking method selected should produce markings that are as permanent as the life expectancy of the device to which they are affixed.

**11.8.6 Time Of Affixing Markings To Identification Plate.** When conditions will not permit marking the device in place, the marking note will indicate that the markings are to be affixed prior to assembly.

**11.8.7 Identification Plate With Markings Is Not Reidentified.** The marking device is not reidentified when markings are affixed at assembly.

**11.9 CONFORMANCE WITH ASME Y14.100 APPENDIX D AND MIL-STD-130 AND WHEN APPLICABLE, MIL-STD-13231 AND MIL-STD-1285 FOR ELECTRONIC ITEMS.**

**11.9.1 Additional Instructions Per MIL-STD-130.** When a contract invokes MIL-STD-130, the following additional instructions apply to the marking of items. Bar coding is not applicable unless otherwise required in the contract or purchase order. Parts shall be individually marked with the applicable design activity CAGE or NSCM, a dash (or slant), PIN and serial number, if applicable.

**11.9.2 Marking Information On Parts When The Manufacturer Is Also The Design Activity.**

a. When the manufacture is the original design activity.

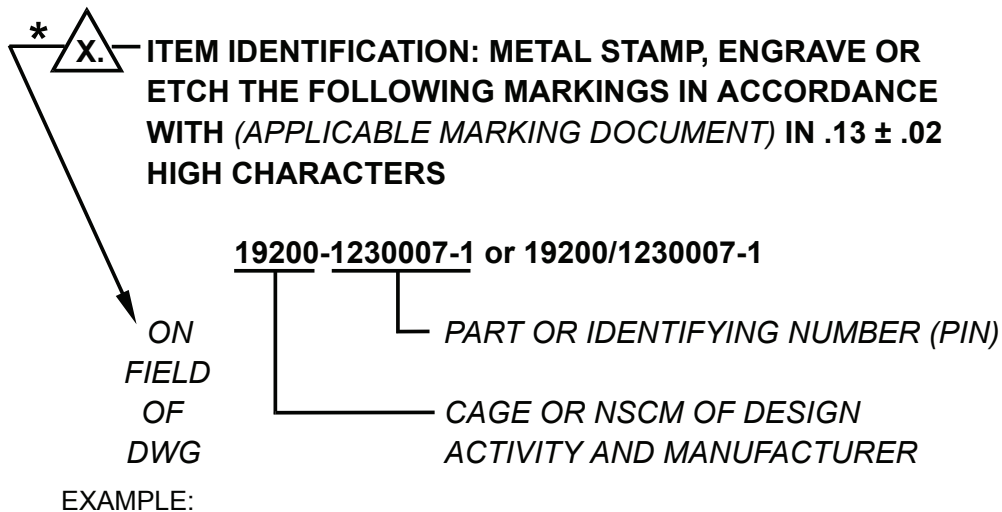

\* A flag note symbol with reference to a General Note listing the above information. Location of information on field of drawing or as a General Note is optional.

b. When manufacturer is the Current Design Activity (CDA) but is not the original design activity.

EXAMPLE:

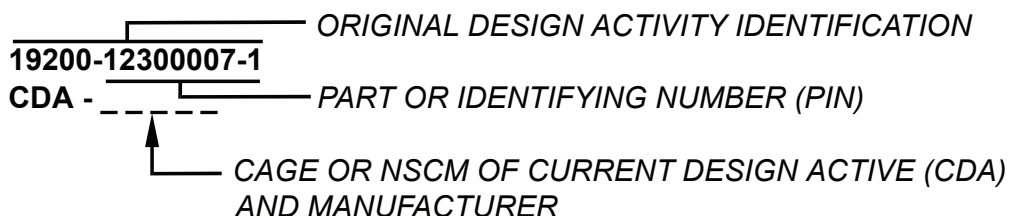



11.9.3 Marking Information On Parts When The Manufacturer Is Other Than The Design Activity.

- a. When the design activity is the original design activity.

EXAMPLE:

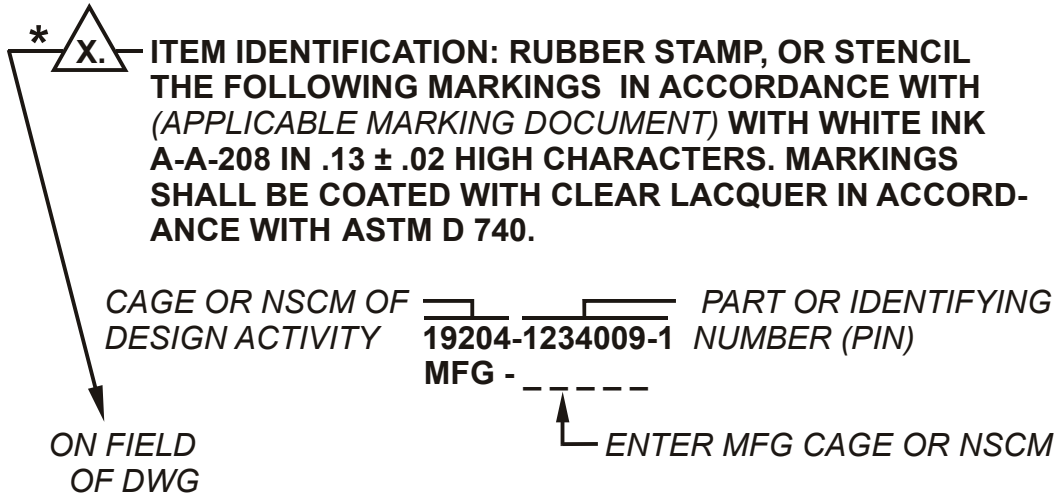

- b. When the design activity is not the original design activity.

EXAMPLE:

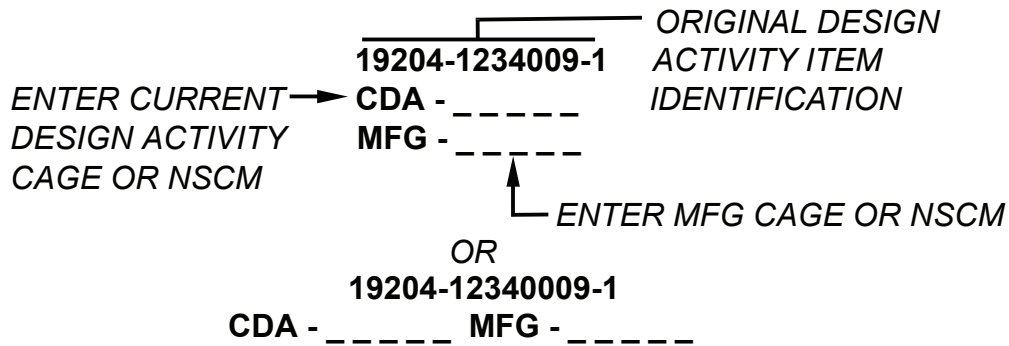

\* A flagnote symbol with reference to a General Note listing the above information. Location of information on field of drawing or as a General Note is optional.



**11.9.4 Marking Information On Parts When The Design Activity Controls The Manufacturers Part Or Assy With A Source Control Drawing (SOCD).**

EXAMPLE:

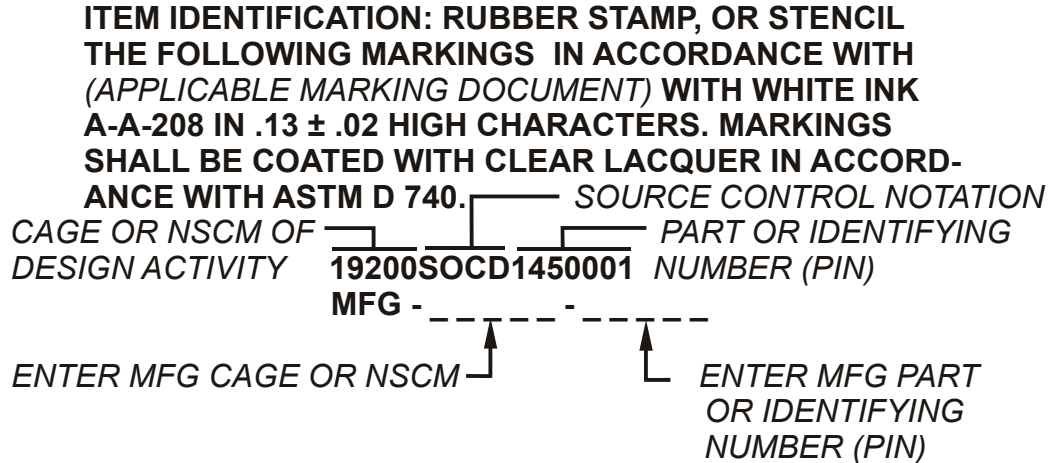

NOTE: All other conditions that are described in the example for PARAGRAPH 11.9.2, apply.

**11.9.5 Marking Information On Parts When The Design Activity Alters Or Selects A Manufacturers Part.**

EXAMPLE:

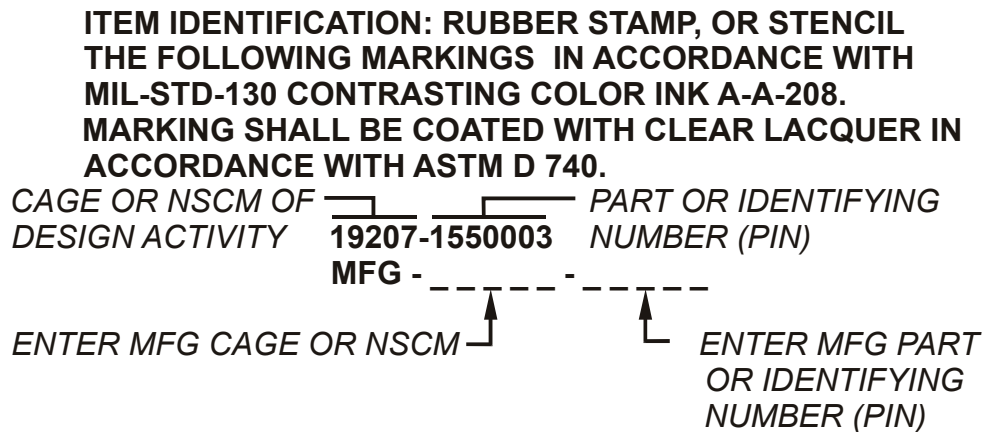

NOTE: All other conditions that are described in the example for PARAGRAPH 11.9.2, apply.





**11.9.6 Marking Information On Printed Wiring Boards.** Drawings pertaining to printed wiring boards shall specify the requirements of PARAGRAPHS 11.9.2 and 11.9.3 and the extent of applicability of MIL-STD-13231.

EXAMPLE:

**ITEM IDENTIFICATION: MARKINGS IN ACCORDANCE WITH MIL-STD-130, AND THE NSN, SHALL BE APPLIED AS SHOWN BELOW, MIL-STD-13231 SHALL NOT APPLY. MARKING LOCATION, METHOD, SIZE AND MATERIAL SHALL BE AS SPECIFIED ON MASTER DWG 12282622.**

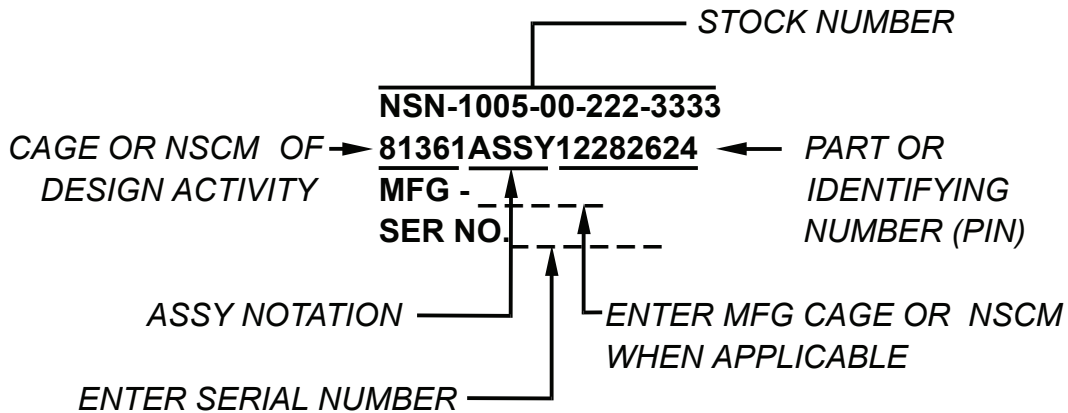

- NOTE: 1. If spacing does not permit relative positioning of markings shown above, the "NSN" and "SER NO" may be located elsewhere on the board.
2. All other conditions that are described in the example for PARAGRAPH 11.9.2, apply.

**11.9.7 Marking Information On Matched Parts.** Matched parts require additional and specific part number markings. The part number of the set as assembled or supplied must be applied to all parts of the matched set. The individual parts shall not have separate, individual part numbers. Drawing requirements for matched parts shall include identification and serial number marking as shown in the following example.

**ITEM IDENTIFICATION: METAL STAMP, ENGRAVE OR ETCH THE FOLLOWING MARKINGS IN ACCORDANCE WITH MIL-STD-130**

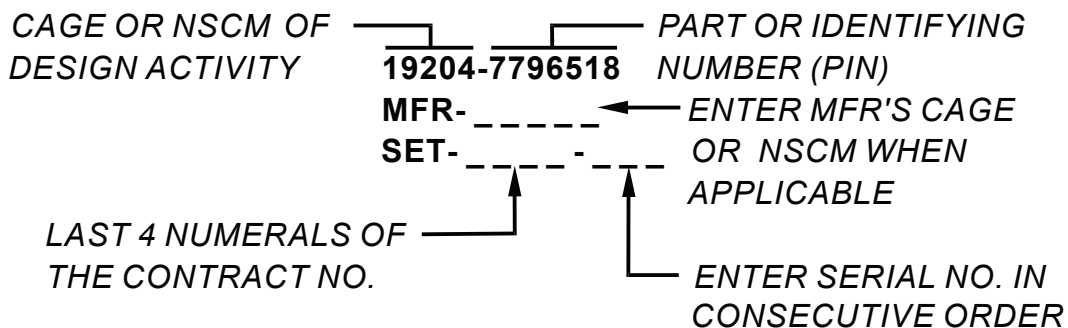

NOTE: All other conditions that are described in the example for PARAGRAPH 11.9.2, apply.



**11.9.8 Marking Information On Parts When The Manufacturer Is Licensed To Manufacture The Design Activities Design Under License - Licensor Agreement.** The requirements of PARAGRAPH 11.9.3 shall apply to the licensee when manufacturing parts in accordance with the licensor's design.

**11.9.9 Marking Information On Parts Procured From The Design Activity, But Not Manufactured By The Design Activity.**

**11.9.9.1 Design Activity Uses Subcontractors But Retains Full Design Control.** When a Design Activity uses subcontractors to manufacture the Design Activity's design but retains full design control, quality assurance control and total responsibility to its customer for the delivered part, the requirements of PARAGRAPH 11.9.2 apply.

**11.9.9.2 Design Activity Uses Subcontractors And Delegates Design Control To Subcontractors.** When the Design Activity delegates the design control, quality control and warranty responsibility to the subcontractor, the requirements of PARAGRAPH 11.9.3 apply.

**11.9.10 Marking Of Electronics Items.** When a contract invokes marking the following documents apply to the marking of items.

- a. Per IPC-2221A and IPC-2222 for rigid single-sided, double-sided, multilayered printed-wiring boards including printed-wiring assemblies constructed from the above boards.
- b. Per MIL-STD-1285 for electrical and electronic parts that are covered by FSC group 59 and possibly FSC 6625.
- c. Per MIL-STD-13231 for the general requirements for marking of electronic items.

**11.9.10.1 Identification Marking Shall Be In Accordance With MIL-STD-130, Except As Modified Herein.** Marking shall include information on a space available basis. Omission of any of this information shall be in accordance with the priority sequence shown in TABLE 11-1.

**11.10 SUBASSEMBLIES, MINOR ASSEMBLIES WHICH DO NOT REQUIRE IDENTIFICATION PLATES.**

**11.10.1 Marking Information On Subassemblies And Minor Assemblies.** Each sub-assembly and assembly shall be individually marked with the information specified in PARAGRAPH 11.9.2 and 11.9.3 except the notation "ASSY" shall be used in place of a dash (or slant) as follows: NOTE: Bar coding is not applicable unless otherwise specified in the contract or purchase order.

EXAMPLE: **ITEM IDENTIFICATION: METAL STAMP THE FOLLOWING MARKINGS IN ACCORDANCE WITH (APPLICABLE MARKING DOCUMENT) IN .13 ± .02 HIGH CHARACTERS.**

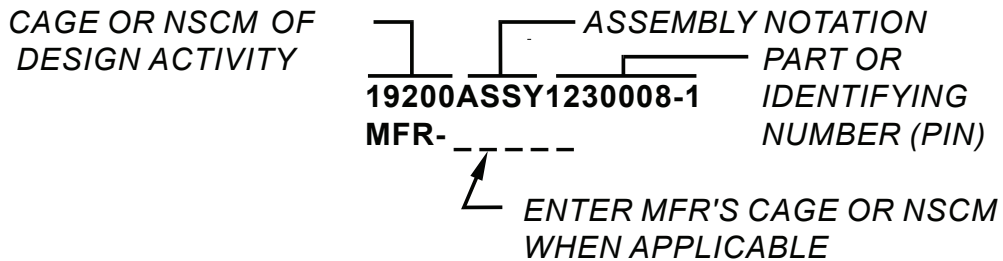

NOTE: All other conditions that are described in the example for PARAGRAPH 11.9.2, apply.



**11.10.2 Assemblies Not Subject To Disassembly.** Inseparable assemblies which are not normally subject to disassembly or repair will be marked as parts. See PARAGRAPHS 11.9.2 and 11.9.3.

**11.10.3 Assemblies That Lack Sufficient Space For Marking.** Assemblies which cannot be marked as specified, the information shall be marked on an identification tag and attached securely to the uninstalled subassemblies or assemblies furnished as spares.

MARKING AND PRIORITY		
TYPE OF PART/ NOMENCLATURE STATUS	ELECTRONIC PARTS	
Standard parts, QPL Parts, MIL Spec Parts, Parts in 59XX Federal 59XX Stock Class and similar parts for which there are established standard marking requirements.	Marking in accordance with specific specification for the part at hand which identifies the part	
Non Standard Parts; Identified by Source Control , Selected Items and Altered Items	1. Design Activity, CAGE Code & Dwg No. /Part No.  2. Actual Manufacturer's CAGE Code. (include Part No. if Applicable)	3. NSN  4. Contract No. & Lot No./Serial No./date code  5. Special Characteristics
Vendor Item Control Drawing (VICD) (Formerly called Specification Control Drawing (SCD)	1. Manufacturer's/Vendors marking 2. Special Characteristics	
Commercial Off-the-Shelf Parts (not specified by Source Control (SOCD) or Vendor Item Control Drawings (VICD)	1. Manufacturer's/Vendor's marking acceptable for parts	
ASSEMBLIES, SUB-ASSEMBLIES, MODULES		
All assemblies, sub-assemblies, modules, printed wiring board assemblies, line replaceable units etc.	1. NSN 2. Serial Number 3. Prime Manufacturer's CAGE Code (include Part No. if applicable) 4. Design Activity CAGE Code/Assy and Dwg No. or Part No.	5. End Item Application ("Part of") 6. Contract No. and Lot No./Date Code 7. Reference Designation 8. Special Characteristics
Commercial, off-the-shelf	1. Manufacturer's/vendor's marking acceptable for assemblies	
JETDS Nomenclature assigned	1. NSN 2. Serial Number 3. Prime Manufacturer's CAGE Code (include Part No., if applicable) 4. Nomenclature (Item Name and type designation)	5.Design Activity CAGE Code & Part Number 6. Contract Number 7. "US Army" 8. Special Characteristics
Commercial, off-the-shelf Equipment, No Army Nomenclature assigned.	1. Prime Manufacturer's Name, LOGO, or Trademark –CAGE Code desirable 2. Manufacturer's Noun Name for device 3. Model Number and Serial Number 4. Special Characteristics/Specifications Data 5. Contract Number	

**NOTE:**

IDENTIFICATION REQUIREMENTS CITED ON THE APPLICABLE PRODUCT DRAWING TAKES PRECEDENCE OVER ALL MARKING PRIORITIES SPECIFIED. FOR LACK OF SPECIFIC DRAWING REQUIREMENTS ITEM SHALL BE MARKED IN ACCORDANCE WITH TABLE 11-1.

PRIORITY OF IDENTIFICATION INFORMATION ON PARTS AND ASSEMBLIES.  
TABLE 11-1



**11.11 MARKING INFORMATION ON UNITS, GROUPS OR SETS AND MAJOR ASSEMBLIES OR ASSEMBLIES SUPPLIED WITH IDENTIFICATION PLATES. (SEE TABLE 11-2)**

**11.11.1 Application of an Identification Plate.** An identification plate is required only when specified by the acquiring activity.

TYPE OF INFORMATION	DRM (REF TO) PARAGRAPH OR SECTION	UNITS	GROUPS OR SETS	MAJOR ASSEMBLIES OR ASSEMBLIES SUPPLIED WITH NAME PLATES
NOMENCLATURE (ITEM NAME)	SECTION 8	X	X	X
DESIGN ACTIVITY'S CAGE OR NSCM CODE NO. & PART NO. (PIN)	SECTION 4,6 & 7	X	X	X
SPECIAL CHARACTERISTICS	11.3.24	*	*	*
STOCK NUMBER (NSN)	11.3.26	*	*	*
MANUFACTURER'S CAGE OR NSCM CODE NO. (IF OTHER THAN DESIGN ACTIVITY)	11.3.12	X	X	X
ACQUISITION INSTRUMENT IDENTIFICATION NUMBER (CONTRACT OR PURCHASE ORDER NUMBER)	11.3.18	X	X	*
SERIAL NUMBER	11.3.22	X	X	*
CONFIGURATION ITEM IDENTIFICATION (CII)	11.3.4	*	*	*
CONTRACTOR'S NAME OR CAGE CODE NUMBER	IF THE MFGR IS NOT THE CONTRACTOR	--	X	--
US	11.3.30	*	*	X

X = REQUIRED

-- = NOT REQUIRED

\* = WHEN SPECIFIED BY PROCUREMENT ACTIVITY

SPECIFIC REQUIREMENTS PER MIL-STD-130

TABLE 11-2



---

## 11.12 EXCEPTIONS TO PARTS BEING INDIVIDUALLY MARKED WITH DESIGN ACTIVITY CAGE NUMBERS.

**11.12.1 Commercial OTS (Off-The-Shelf).** These parts present no identification problem and may be excluded unless otherwise specified by contract or order.

**11.12.2 Parts Within An Assembly Or Subassembly.** These parts are not normally subject to removal, replacement or repair.

## 11.13 APPLICATION OF SAE AS478 (SOCIETY OF AEROSPACE ENGINEERS:)

**11.13.1 Additional Instructions Per SAE AS478.** When a contract invokes SAE AS478, the following additional instructions apply to the marking of items in accordance with TABLE 11-3.

**11.13.2 Method Of Marking.** To specify marking in accordance with SAE AS478, the document number followed by a method number and/or class letter shall be used. Specific data to be marked will be included with the reference to this standard. Typical callouts & examples that are shown are in accordance with TABLE 11-3.

- a. **MARK PART NO. PER SAE AS478-2C1** - calls for marking by a metal stamp roll, shallow only.
- b. **MARK PART & SERIAL NO. PER SAE AS478 CLASS H** - calls for marking by any method in Column H.
- c. **MARK MATERIAL CODE PER SAE AS478-2C1-D** - calls for marking by method 2C1 and allows alternative methods listed in column D.
- d. **MARK MATERIAL CODE PER SAE AS478-2C1-H** - calls for marking by method 2C1 and allows alternative methods in Column H. See PARAGRAPH 11.13.7.
- e. **MARK MATERIAL CODE PER SAE AS478-7A1 OCR-A1** - calls for marking by intermediate electrochemical etch with optical recognized fonts. See PARAGRAPHS 11.8.3.2 and 11.8.3.3.

**11.13.3 First Tier Marking Methods.** When a marking method number in the 1st Tier is specified, any of its subordinate methods listed in the TABLE 11-3 may be used.

EXAMPLE: When method 2 is specified, this permits marking by any of its 2nd Tier subordinates 2A, 2B, 2C, 2D, 2E, 2F or any of its 3rd Tier subordinates 2A1 through 2F3.

**11.13.4 Second Tier Marking Methods.** When a marking method number in the 2nd Tier is specified, any of its subordinates in the 3rd Tier may be used.

Example: When 2C is specified, either 2C1 or 2C2 may be used.

i.e. MARK PART NUMBER PER SAE AS478-2C.

**11.13.5 Third Tier Marking Methods.** When a marking method in the 3rd Tier is specified, only that method may be used.

**11.13.6 Class Letter Marking Methods.** When a class letter or letters are specified, any of the marking methods indicated by "X" in the column under the class letter may be used. The limits for marking depths for the actual method used shall apply.

Example: Class letter H - permits marking methods 2C1, 2D1, 2E2, 2F3, 3B2, 5B2, 7A2, 7C2, 8B and 8C to be used. If method 2E2 is the actual method used, depth limits of .002-.006 inch (0.05-0.15 mm) shall apply. If method 2C1 is the method used, depth limits of .001-.006 inch (0.03-0.15 mm) shall apply.



**11.13.7 Depths and Alternative Methods of Marking.** The alternative methods and recommended marking depths are given in TABLE 11-3. The choice of alternatives is not limited to those recommended in the TABLE 11-3 column headed "SEE NOTE 1".

**11.13.8 Optical Character Recognition (OCR) (Bar Coding)** SAE marking requirements are in accordance with ANSI X3.17 (INACTIVE) for the standard OCR-A character set. The OCR-A marking character's height, width, spacing and positioning are specified. See PARAGRAPH 11.13.2e for designating a bar code marking requirement.

METHOD NO.			PARA REF	SEE NOTE 1	METHOD	DEPTH				CLASS LETTER																	
1st TIER	2nd TIER	3rd TIER				INCH		MILLIMETRE		A	B	C	D	E	F	G	H	J	K	L	M	N	P	R			
						MIN	MAX	MIN	MAX																		
1	1A	1A1 1A2	11.6.1	— — A A	PERMANENT MARKING METHODS SEE PARA 11.6.1 INTEGRAL LIGHT RAISED DEPRESSED	.005	.010	0.13	0.25	X																	
						.005	.010	0.13	0.25	X																	
	1B	1B1 1B2	— —	INTERMEDIATE RAISED DEPRESSED	.008	.035	0.20	0.89																			
	1C				HEAVY (RAISED ONLY)	.030	.130	0.8	3.3																		
2	2A	2A1 2A2	11.6.1.2 11.6.1.2a	— — B C	METAL STAMP HAMMER SHALLOW DEEP	.001	.006	0.03	0.15		X																
						.004	.010	0.10	0.25	X	X																
	2B	2B1 2B2	11.6.1.2b	— D E	PRESS SHALLOW DEEP	.001	.006	0.03	0.15		X		X														
		2C1 2C2	11.6.1.2c	— D E	ROLL SHALLOW DEEP	.001	.006	0.03	0.15		X		X		X	X	X										
		2D1 2D2	11.6.1.2d	— D E	VIBRO PEEN, MANUAL SHALLOW DEEP	.001	.006	0.03	0.15		X		X		X		X										
	2E1 2E2	11.6.1.2e	— —	VIBRO PEEN, CONTROLLED SHALLOW DEEP	(a) .002	.002 .006	(a) 0.05	0.05 0.15		X	X	X		X		X					X						
	2F	2F1 2F2 2F3	11.6.1.2f	— — —	DOT-PEENING SHALLOW INTERMEDIATE DEEP	(a) 0.001 0.002	0.002 0.004 0.006	(a) 0.03 0.05	0.05 0.10 0.15		X	X		X	X	X		X	X								
	3A		11.6.1.3 11.6.1.3a	— F	ENGRAVE MANUAL	.0005	.006	0.013	0.15		X			X													
						3B	3B1 3B2	11.6.1.3b	— G H	CONTROLLED SHALLOW DEEP	.0005 .002	.003 .006	0.013 0.05	0.08 0.15		X	X		X	X		X	X				
	4A	4A1 4A2	11.6.1.4 11.6.1.4a	— — —	ELECTRIC ARC SCRIBE MANUAL SHALLOW DEEP	.001	.003	0.03	0.08																		
						4B	4B1 4B2	11.6.1.4b	— M —	CONTROLLED SHALLOW DEEP	.0005 .001	.001 .006	0.013 0.03	0.03 0.15												X	

TABLE 11-3 SPECIFIC REQUIREMENTS PER SAE AS478 (Continued on next page)



(Continued from previous page)

METHOD NO.			PARA REF	SEE NOTE 1	METHOD PERMANENT MARKING (CONTINUED)	DEPTH				CLASS LETTER														
1st TIER	2nd TIER	3rd TIER				INCH		MILLIMETRE		A	B	C	D	E	F	G	H	J	K	L	M	N	P	R
						MIN	MAX	MIN	MAX															
5	5A		11.6.1.5	—	<b>SCRIBE</b>																			
			11.6.1.5a	F	MANUAL	.001	.006	0.03	0.15	X				X										
	5B		11.6.1.5b	—	<b>CONTROLLED</b>																			
		5B1 5B2 5B3		G J —	SHALLOW DEEP EXTRA SHALLOW	.001 .002 .0002	.003 .006 .0007	0.03 0.05 .005	0.08 0.15 .018		X	X	X	X	X	X					X			
6	6A 6B 6C		11.6.1.6	—	<b>ACID ETCH</b>																			
				K	SHALLOW	(a)	.0005	(a)	0.013													X	X	
				L	INTERMEDIATE DEEP	.0005 .001	.001 .003	0.013 0.03	0.03 0.08														X X	
7	7A		11.6.1.7	—	<b>ELECTROCHEMICAL</b>																			
			11.6.1.7a	—	<b>ETCH</b>																			
			7A1 7A2 7A3	— — —	SHALLOW INTERMEDIATE DEEP	(a) .0003 .001	.0003 .0015 .003	(a) 0.008 0.03	0.008 0.038 0.08		X		X	X	X	X					X	X		
		7B		11.6.1.7b	—	<b>DEPOSIT (RAISED) INACTIVE FOR NEW DESIGN</b>	(a)	.0004	(a)	0.010													X	
		7C		11.6.1.7c	— — —	<b>AC ETCH</b> SHALLOW INTERMEDIATE DEEP	(a) .0003 .001	.0003 .0015 .003	(a) 0.008 0.03	0.008 0.038 0.08		X		X	X	X	X				X	X		
	7D		11.6.1.7d		<b>AC ETCH—DC DEPOSIT</b>	(a)	.0005	(a)	0.013													X		
8	8A 8B 8C		11.6.1.8	—	<b>BLAST</b>																			
				K G G	SHALLOW DEEP INTERMEDIATE	(a) .001 .0003	.0005 .003 .001	(a) 0.03 0.008	0.013 0.08 0.03		X		X	X	X	X					X	X		
9	9A		11.6.1.9	—	<b>BRAND</b>																			
			11.6.1.9a	—	HOT PRESS	.001	.010	0.03	0.25															
10			11.6.1.10	—	<b>CERAMIC</b>																			
11			11.6.1.11	—	<b>DECALOMANIA</b>																			
12			11.6.1.12	—	<b>PLATE</b>																			
13			11.6.1.13	—	<b>BAND</b>																			
14			11.6.1.14	—	<b>PRESSURE SENSITIVE LABEL</b>																			
15	15A		11.6.1.15	—	<b>LASER</b>																			
			11.6.1.15a	—	<b>DOT MATRIX MODE</b>																			
			15A1 15A2 15A3	— — —	SHALLOW INTERMEDIATE DEEP	.0001 .0004 .001	.0003 .001 .003	0.003 0.010 0.03	0.008 0.03 0.08															
	15B		11.6.1.15b	—	<b>ENGRAVE MODE</b>																			
			15B1 15B2 15B3		— — —	SHALLOW INTERMEDIATE DEEP	.0001 .0007 .004	.0006 .004 .010	0.003 0.018 0.10	0.015 0.010 0.25														
16			11.6.1.16	—	<b>PLASTIC LAMINATE</b>																			

SPECIFIC REQUIREMENTS PER SAE AS478  
 TABLE 11-3 (Continued on next page)



(Continued from previous page)

METHOD NO.			PARA REF	SEE NOTE 1	METHOD	DEPTH				CLASS LETTER																	
1st TIER	2nd TIER	3rd TIER				INCH		MILLIMETRE		A	B	C	D	E	F	G	H	J	K	L	M	N	P	R			
						MIN	MAX	MIN	MAX																		
29			11.6.2	—	TEMPORARY MARKING METHODS SEE PARA 11.6.2 ANY TEMPORARY METHOD																						
30			11.6.2.1	—	INK																						
31			11.6.2.2	—	DYE																						
32			11.6.2.3	—	PAIN																						
32A			11.6.3.2.1	—	SILK SCREEN																						
33			11.6.2.4	—	CHALK																						
34			11.6.2.5	—	CRAYON																						
35			11.6.2.6	—	TAG																						
	35A			N	NONMETALLIC TAG & STRING																						
	35B			—	NONMETALLIC TAG & WIRE																						
	35C			P	METALLIC TAG & WIRE																						
	35D			—	BAG ITEM & TAG (b)																						
36			11.6.2.7	—	BAND OR TAPE																						
	36A			N	NONMETALLIC																						
	36B			P	METALLIC																						
37			11.6.3	—	PACKAGE	(b)																					

SPECIFIC REQUIREMENTS PER SAE AS478  
TABLE 11-3

Note 1. This column indicates recommended class letter columns which contain suitable alternatives for the individual marking methods. Alternatives may be used only when a class letter is used in a drawing call-out. See PARAGRAPHS 11.13 and 11.13.7.

a. Depth sufficient to provide marking that is discernible without magnification.

b. Marking per method 35D is permissible where method 37 is specified.





**11.14 WARRANTED ITEMS.**

**11.14.1 Warranted Item Markings.** When specifically required by a contract statement of work, purchase order or other contract clause, warranted items shall be marked in a conspicuous location to give notice that the item(s) are subject to warranty. The marking shall contain, as a minimum, the statement “WARRANTED ITEM” and the period or conditions of warranty (i.e., hours of operation, cycles of operation, time since manufactured, etc.) (See FIGURE 11-4.)

**WARRANTED ITEM**  
**THIS ITEM IS UNDER WARRANTY**  
**UNTIL \_\_\_\_\_ (See NOTE 1)**

**WARRANTED ITEM**  
**THIS ITEM IS UNDER WARRANTY**  
**UNTIL \_\_\_\_\_ (See NOTE 2)**  
**HAS BEEN COMPLETED.**

NOTES:

1. Indicate expiration date.
2. Indicate condition of use (i.e., hours of operation, time since manufacture).

WARRANTED ITEM IDENTIFICATION  
FIGURE 11-4

**11.15 SECURITY CLASSIFICATION.**

**11.15.1 Security Classification Markings.** When required by the acquisition document, classified items shall be marked in a conspicuous manner to provide notice that the item(s) are subject to security restrictions. Classified marking shall be in accordance with DOD 5220.22-M. See SECTION 6, PARAGRAPH 6.13.



**11.16 ELECTROSTATIC DISCHARGE CONTROL (ESD) PROGRAM.**

**11.16.1 Sensitive Electronic Device Marking on Parts.** Electrical and electronic parts classified as sensitive to damage from electrostatic discharge in accordance with MIL-STD-1686 and MIL-HDBK-263 shall be marked with the ESD symbol per EIA-471. The choice of color is arbitrary, however, a black symbol on a yellow background is preferred. See FIGURE 11-5.

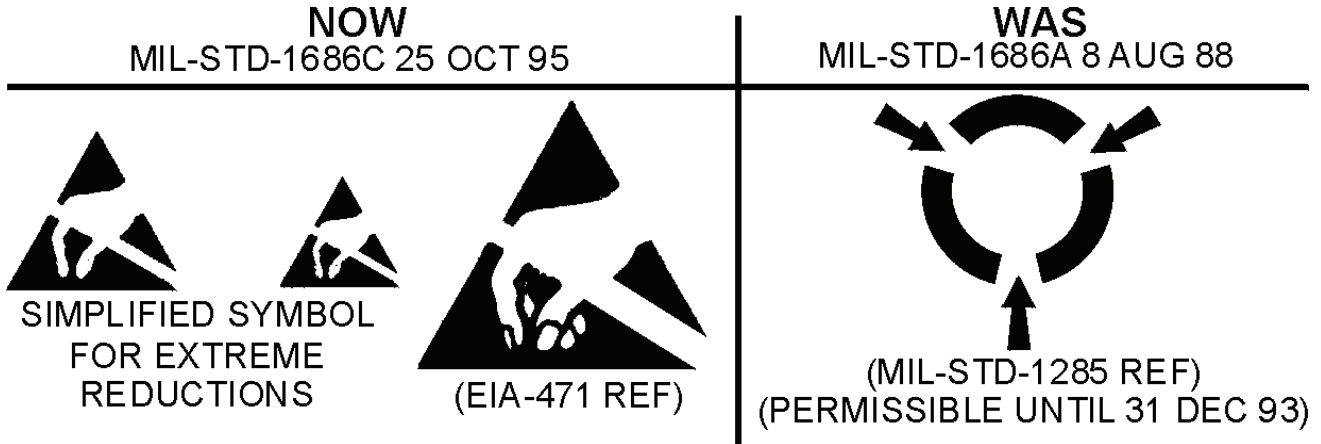

ELECTROSTATIC DISCHARGE (ESD) SYMBOL  
FIGURE 11-5

**11.16.1.1 Assemblies Containing ESD Parts.** Assemblies containing ESD parts shall be marked with the ESD symbol. This symbol shall be so located as to be readily visible when the assembly is installed in its next higher assembly, if applicable. When the physical size of the assembly precludes direct marking of the ESD symbol, the symbol shall be marked on an identification tag which shall be securely attached to the assembly. The ESD unit pack shall be marked as specified in MIL-STD-129.

**11.16.1.2 Equipment Enclosures Containing ESD Parts or Assemblies.** Equipment enclosures containing ESD parts or assemblies shall be marked with the ESD symbol and a ESD label as shown on FIGURE 11-6. The symbol and caution note (when space permits) shall be located in such a position as to be readily visible to personnel prior to gaining access to the ESD parts or assemblies. Where space permits, these markings shall be on the access door or cover of the equipment enclosure.

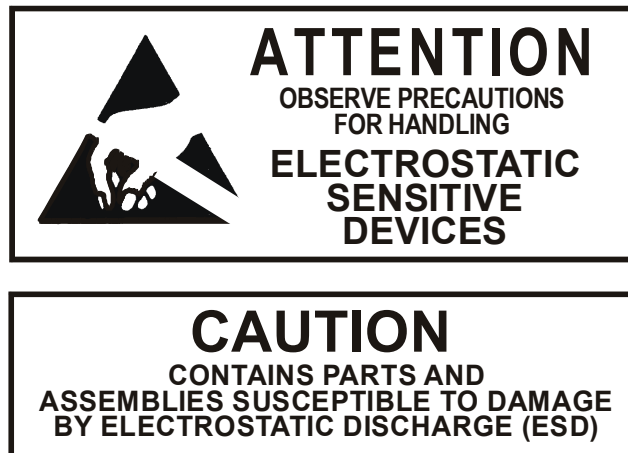

ELECTROSTATIC DISCHARGE (ESD) LABEL AND CAUTION STATEMENT  
FIGURE 11-6