



**14.1 SCOPE.**

**14.1.1 Purpose.** This section delineates the application of the approved welding symbols for use on drawings.

**14.2 APPLICABLE DOCUMENTS.** Note: DoD Policy Memo 05-3 “Elimination of Waivers to Cite Military Specifications and Standards in Solicitation and Contracts” has eliminated the need for waivers to use MIL-SPECS and MIL-STDS on DoD contracts (See PREFACE 1, Section 2)

AWS A1.1	Metric Practice Guide for the Welding Industry
AWS A2.4	Symbols for Welding Brazing and Nondestructive Examination
AWS A3.0	Welding Terms and Definitions
AWS A5.30	Specification for Consumable Inserts (INACTIVE)
ISO 128	Engineering Drawing, Principals of Presentation
ISO 2553	Welded, Brazed and Soldered Joints- Symbolic Representation on Drawings

**14.3 USA & INTERNATIONAL (ISO) IMPLICATIONS.**

**14.3.1 Position Of The Weld Symbol.** Special emphasis should be placed on positioning of the "Weld Symbol" in relation to the "Welding Symbol Reference Line" (weld placed on "Arrow Side" or weld placed on "Other Side" of joint) when interpreting INCH (U.S.) or METRIC (ISO) drawings. See FIGURE 14-1.

Note: AWS A2.4-2007 applies to drawings prepared using inch or metric (SI) units, and ISO 2553-1992 applies to metric (SI) units only. AWS A2.4-1998 also applied to inch and metric (SI) units.

**WELD SYMBOL**

APPLIES TO  
INCH OR METRIC

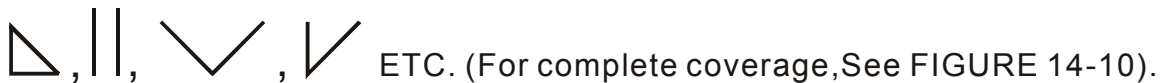

DISTINCTION BETWEEN "WELD SYMBOL" AND "WELDING SYMBOL.  
FIGURE 14-1. (Continued Next Page.)

Note: AWS A2.4 defines the entire specification added to the drawing (leader, weld symbol, sizes, codes, notes, etc.) as the “welding symbol” – it is the full symbolic representation of the welding requirements for the weld to be applied. Thus, in AWS terminology, the “weld symbol” is the symbol used to represent the type of weld, and this symbol is used as part of a “welding symbol”, which represents the complete requirement. ISO 2553 is not so careful with the distinction between these two terms, and refers to the “weld symbol” described above as a “weld symbol” in paragraph 6.1 of the standard and as a “welding symbol” in Figure 3 of the standard. In general, the ISO standard is less precise in the use of these terms. This does not sacrifice the validity of the standard; however, it may lead to confusion when discussing welding requirements with others.

FIGURE 14-1 (Continued)

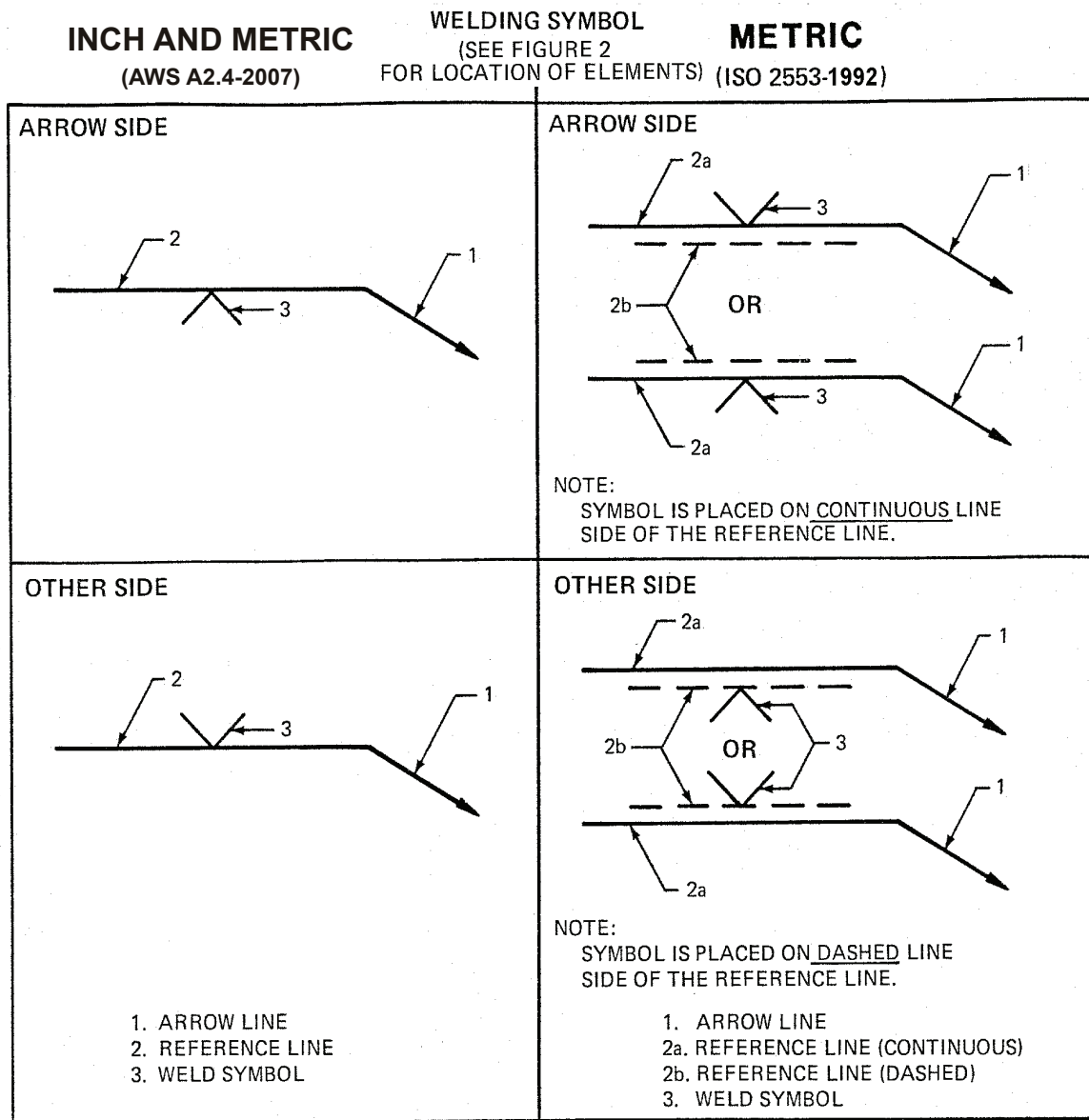

DISTINCTION BETWEEN "WELD SYMBOL" AND "WELDING SYMBOL".  
 FIGURE 14-1 (Continued from previous page.)

**14.3.2 Release Of ISO 2553-1984 And Cancellation Of ISO 2553-1974.** With the release of ISO 2553-1984 Second Edition and subsequently the third edition 1992, the ISO 2553-1974 first edition was canceled and replaced by the 1992 third edition which is a technical revision and the following regulations apply:

**14.3.2.1 Dual Reference Line System.** The dual reference line system implemented by ISO 2553-1984 still prevails in the 1992 revision, and consists of two parallel reference lines, one continuous and one dashed. The dashed line appears either above or below the continuous line. The dashed line is only required for asymmetrical welds – it may be omitted for symmetrical welds.

i.e. ----- or -----



**14.3.2.2 Weld Symbol Placement Per ISO 2553.** For asymmetrical welds, the Weld Symbol is attached to the reference line or the identification line as follows:

- a. The Weld Symbol is placed on the continuous reference line if the weld (weld face) is on the arrow side of the joint. See FIGURE 14-1.
- b. The Weld Symbol is placed on the dashed reference line if the weld (weld face) is on the other side of the joint. See FIGURE 14-1.

**14.3.3 Positioning Of The Dashed Line Per ISO 2553-1992.** When converting drawings from ISO 2553-1974 Methods "E" or "A" into the new system presented in ISO 2553-1992 the addition of a "dashed line" below or above the "unbroken line" shall govern whether the weld is on the "arrow side" or "other side" of the joint, respectively. (The foregoing method replaces the position of the symbol as the governing factor for establishing on which side of joint the weld was made per ISO 2553-1974). However, the position of the weld symbol per AWS A2.4-1998 still remains the governing factor for drawings that reference AWS A2.4-1998 or a later revision such as 2007. See TABLE 14-1.

**14.3.4 Illustrated Examples Of Conversion.** Only a few examples are presented (TABLE 14-1, Examples 1 & 2) to illustrate the procedure used during the conversion period or until ISO 2553-1974 First Edition has been phased out. It is especially important for fillet welds to add the letter "a" or "z" in front of that dimension because the use of dimensioning leg length (z) or throat thickness (a) has been connected with the position of the weld symbol on the reference line. See TABLE 14-1, Example 3. All other weld symbol representations for conversion purposes are similar to the examples shown. For symmetrical welds, the dashed line is omitted. See TABLE 14-1, Example 4.



GUIDANCE FOR CONVERTING DRAWINGS MADE TO THE "WAS" ISO 2553-1974 TO THE "NOW" ISO 2553-1992 SYSTEM			
	INCH AND METRIC (AWS A2.4-2007)	METRIC (WAS) (ISO 2553-1974) USE DASHED LINE TO CONVERT SYMBOLS FOR ASYMMETRICAL WELD	METRIC (NOW) (ISO 2553-1992) DUAL LINES REQUIRED FOR ASYMMETRICAL WELDS
EXAMPLE 1	TO BE WELDED ON THE ARROW SIDE	METHOD "E" 	 OR 
		METHOD "A" 	
	TO BE WELDED ON THE OTHER SIDE	METHOD "E" 	 OR 
		METHOD "A" 	
EXAMPLE 2	TO BE WELDED ON THE ARROW SIDE	METHOD "E" 	 OR 
		METHOD "A" 	
	TO BE WELDED ON THE OTHER SIDE	METHOD "E" 	 OR 
		METHOD "A" 	
EXAMPLE 3	TO BE WELDED ON THE ARROW SIDE	METHOD "E" 	 OR 
		METHOD "A" 	
	TO BE WELDED ON THE OTHER SIDE	METHOD "E" 	 OR 
		METHOD "A" 	

COMPARISON BETWEEN AWS "INCH & METRIC" CONVERSION METHODS  
AND CURRENT "METRIC" METHODS"  
TABLE 14-1 (Continued Next Page.)

GUIDANCE FOR CONVERTING DRAWINGS MADE TO THE "WAS" ISO 2553-1974 TO THE "NOW" ISO 2553-1992 SYSTEM			
	INCH AND METRIC (AWS A2.4-2007)	METRIC (WAS) (ISO 2553-1974)	METRIC (NOW) (ISO 2553-1992)
EXAMPLE 4			
NOTE	ALL OTHER "WELD SYMBOL" REPRESENTATIONS FOR CONVERSION PURPOSES ARE GENERALLY SIMILAR TO EXAMPLES 1 & 2 AND ARE OMITTED FROM BECOMING REPETITIOUS.		

- 1/ PREFERRED ON U.S. DRAWINGS WHICH COMPLY WITH THE PRINCIPLES OF ISO 2553-1974 AND THIRD ANGLE PROJECTION.
- 2/ FILLET WELDS SHALL ALWAYS BE PRECEDED BY THE LETTERS "a" OR "z" PLACED IN FRONT OF THE VALUE OF THE CORRESPONDING DIMENSION. THE DIMENSION FOLLOWING THE SYMBOL INDICATES LENGTH OF THE WELD. IN THE ABSENCE OF ANY INDICATION FOLLOWING THE SYMBOL SIGNIFIES THAT THE WELD IS CONTINUOUS OVER THE WHOLE LENGTH OF THE WORKPIECE.

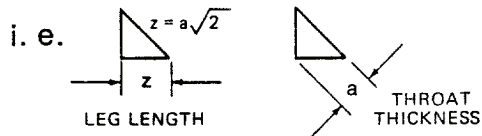

- 3/ FOR SYMMETRICAL WELDS THE DASHED LINE IS UNNECESSARY AND IS OMITTED.

COMPARISON BETWEEN AWS "INCH & METRIC" CONVERSION METHODS  
AND CURRENT "METRIC" METHODS"  
 TABLE 14-1 (Continued from previous page.)

**14.4 DEFINITIONS.** (Alphabetically Listed) See AWS A3.0 for additional definitions.

**14.4.1 Arc Welding (AW).** A group of welding processes that produces coalescence of workpieces by heating them with an arc. The processes are used with or without the application of pressure and with or without filler metal. See also Master Chart of Welding and Allied Processes.

**14.4.2 Atomic Hydrogen Welding (AHW).** An arc welding process that uses an arc between two metal electrodes in a shielding atmosphere of hydrogen and without the application of pressure. This is an obsolete or seldom used process.

**14.4.3 Back Weld.** A weld deposited at the back of a single groove weld. See PARAGRAPH 14.9.1.8.

**14.4.4 Bare Metal Arc Welding (BMAW).** An arc welding process that uses an arc between a bare or lightly coated electrode and the weld pool. The process is used without shielding, without the application of pressure, and filler metal is obtained from the electrode. This is an obsolete or seldom used process.

**14.4.5 Base Material.** The material to be welded, brazed, soldered, or cut. See also Base Metal and Substrate.

**14.4.6 Base Metal.** The metal to be welded, brazed, soldered, or cut. The use of this term implies that materials other than metals are also referred to where appropriate. See also Base Material and Substrate.

**14.4.7 Bevel.** An angular type of edge preparation. See FIGURE 14-7.

**14.4.8 Bevel Angle.** The angle formed between the prepared edge of a member and a plane perpendicular to the surface of the member. See PARAGRAPH 14.11.



**14.4.9 Braze Welding.** A welding process variation that uses a filler metal with a liquidus above 450 °C (840 °F) and below the solidus of the base metal. The base metal is not melted. Unlike brazing, in braze welding; the filler metal is not distributed in the joint by capillary action.

**14.4.10 Carbon Arc Welding (CAW).** An arc welding process that uses arc between a carbon electrode and the weld pool. The process is used with or without shielding and without the application of pressure.

**14.4.11 Coalescence.** The growing together or growth into one body of the materials being welded.

**4.4.12 Cold Welding (CW).** A solid-state welding process in which pressure is used to produce a weld at room temperature with substantial deformation at the weld. See also **Diffusion Welding** and **Forge Welding**.

**14.4.13 Complete Fusion.** Fusion over the entire fusion faces and between all adjoining weld beads. See PARAGRAPH 14.9.2.4.

**14.4.14 Complete Joint Penetration.** Penetration of weld metal through the thickness of a joint with a groove weld. See PARAGRAPH 14.9.2.4.

**14.4.15 Concave Fillet Weld.** A fillet weld having a concave face. See PARAGRAPH 14.9.2.6.

**14.4.16 Concave Root Surface.** A root surface which is concave.

**14.4.17 Continuous Weld.** A weld which extends continuously from one end of a joint to the other. Where the joint is essentially circular, it extends completely around the joint.

**14.4.18 Convex Fillet Weld.** A fillet weld having a convex face. See PARAGRAPH 14.9.2.6.

**14.4.19 Convex Root Surface.** A root surface which is convex.

**14.4.20 Corner-Flange Weld.** A flange weld with only one member flanged at the location of welding. See PARAGRAPH 14.9.1.2.

**14.4.21 Corner Joint.** A joint between two members located approximately at right angles to each other. See TABLE 14-2.

**14.4.22 Diffusion Brazing (DFB).** A brazing process that forms liquid braze metal by diffusion between dissimilar base metals or between base metal and filler metal pre-placed at the faying surfaces. The process is used with the application of pressure.

**14.4.23 Diffusion Welding (DFW).** A solid-state welding process that produces a weld by the application of pressure at elevated temperature with no macroscopic deformation or relative motion of the workpieces. A filler metal may be inserted between the faying surfaces. See also **Cold Welding** and **Forge Welding**.

**14.4.24 Edge-Flange Weld.** A flange weld with two members flanged at the location of welding. See PARAGRAPH 14.9.1.2.

**14.4.25 Edge Joint.** A joint between the edges of two or more parallel or nearly parallel members. See TABLE 14-2.

**14.4.26 Edge Preparation.** The surface prepared on the edge of a member for welding.

**14.4.27 Edge Weld.** A weld in an edge joint. See TABLE 14-2.

**14.4.28 Effective Length Of Weld.** The length of weld throughout which the correctly proportioned cross section exists. In a curved weld, it shall be measured along the axis of the weld.



- 14.4.29 Face Of Weld.** The exposed surface of a weld on the side from which welding was done.
- 14.4.30 Faying Surface.** The mating surface of a member which is in contact or in close proximity to another member to which it is to be joined.
- 14.4.31 Filler Metal.** The metal to be added in making a welded, brazed, or soldered joint. See **Electrode, Welding Rod, Backing Filler Metal, Brazing Filler Metal, Diffusion Aid, Solder,** and **Spray deposit.**
- 14.4.32 Fillet Weld.** An approximately triangular cross-section weld joining two surfaces approximately at right angles to each other in a lap joint, T-joint, or corner joint. See PARAGRAPH 14.9.1.3.
- 14.4.33 Flange Weld.** A weld made on the edges of two or more members to be joined, usually light gauge metal, when at least one of the members is flanged. See PARAGRAPH 14.9.1.2.
- 14.4.34 Flare-Bevel Groove Weld.** A weld in a groove formed by a member with a curved surface in contact with a planar member. See TABLE 14-2.
- 14.4.35 Flare -V- Groove Weld.** A weld in a groove formed by two members with curved surfaces. See TABLE 14-2.
- 14.4.36 Flash.** The material which is expelled or squeezed out of weld joint and which forms around the weld.
- 14.4.37 Flash Welding (FW).** A resistance welding process that produces a weld at the faying surfaces of a butt joint by a flashing action and by the application of pressure after heating is substantially completed. The flashing action, caused by the very high current densities at small contact points between the workpieces, forcibly expels the material from the joint as the workpieces are slowly moved together. The weld is completed by a rapid upsetting of the workpieces.
- 14.4.38 Forge Welding (FOW).** A solid-state welding process that produces a weld by heating the workpieces to welding temperature and applying blows sufficient to cause permanent deformation at the faying surfaces. See also Cold Welding and Diffusion Welding.
- 14.4.39 Fusion.** The melting together of filler metal and base metal (substrate), or of base metal only, which results in coalescence.
- 14.4.40 Fusion Face.** A surface of the base metal which will be melted during welding.
- 14.4.41 Fusion Welding.** Any welding process or method which uses fusion to complete the weld.
- 14.4.42 Fusion Zone.** The area of base metal melted as determined on the cross section of a weld.
- 14.4.43 Gas Carbon Arc Welding (CAW-G).** A carbon arc welding process variation that uses a shielding gas. This is an obsolete or seldom used process.
- 14.4.44 Groove Angle.** The total included angle of the groove between parts to be joined by a groove weld. See PARAGRAPH 14.11.2.
- 14.4.45 Groove Face.** That surface of a joint member included in the groove.
- 14.4.46 Groove Radius.** The radius used to form the shape of a “J”- or “U”-groove weld joint.
- 14.4.47 Groove Type.** The geometric configuration of a groove.



**14.4.48 Groove Weld.** A weld made in the groove between two members to be joined. The standard types of groove welds are as follows: See PARAGRAPH 14.9.1.1.

- a. double-bevel-groove weld
- b. double-flare-bevel-groove weld
- c. double-flare-V-groove weld
- d. double-J-groove weld
- e. double-U-groove weld
- f. double-V-groove weld
- g. single-bevel-groove weld
- h. single-flare-bevel-groove weld
- i. single-flare-V-groove weld
- j. single-J-groove weld
- k. single-U-groove weld
- l. single-V-groove weld
- m. square-groove weld

Note: ISO 2553 mistakenly calls groove welds “butt welds.” In the terminology that has been so carefully developed for use in AWS standards, such as AWS A2.4, there is a “butt joint”, which is commonly welded using various types of a “groove weld.” Thus we have the official terms “butt joint” and “groove weld.” ISO seems to have lost this distinction. The term “butt weld” is also commonly used in the U.S., but it is technically incorrect; the correct term is “groove weld”. Usually “butt weld” is used to refer to a “square groove weld”, which is where the joint surfaces are not prepared by chamfering, beveling, removing J- or U-shaped cross-sections, etc.

**14.4.49 Intermittent Weld.** A weld in which the continuity is broken by recurring unwelded spaces. See FIGURE 14-14.

**14.4.50 Joint.** The junction of members or the edges of members which are to be joined or have been joined. See TABLE 14-2.

**14.4.51 Joint Design.** The joint geometry together with the required dimensions of the welded joint.

**14.4.52 Joint Penetration.** The minimum depth a groove or flange weld extends from its face into a joint, exclusive of reinforcement. Joint penetration may include root penetration. See also **Complete Joint Penetration, Root Penetration, and Effective Throat.**

**14.4.53 Lap Joint.** A joint between two overlapping members. See TABLE 14-2.

**14.4.54 Leg Of A Fillet Weld.** The distance from the root of the joint to the toe of the fillet weld.

**14.4.55 Melt-Thru.** Complete joint penetration for a joint welded from one side. Visible root reinforcement is produced. See PARAGRAPH 14.9.2.4.

**14.4.56 Plug Weld.** A circular weld made through a hole in one member of a lap or T-joint fusing that member to the other. The walls of the hole may or may not be parallel and the hole may be partially or completely filled with weld metal. (A fillet welded hole or a spot weld should not be construed as conforming to this definition.) See PARAGRAPH 14.9.1.4.

**14.4.57 Resistance Seam Welding (RSEW).** A resistance welding process that produces a weld at the faying surfaces of overlapped parts progressively along a length of a joint. The weld may be made with overlapping weld nuggets, a continuous weld nugget, or by forging the joint as it is heated to the welding temperature by resistance to the flow of the welding current. See PARAGRAPH 14.9.1.6.

**14.4.58 Resistance Spot Welding (RSW).** A resistance welding process that produces a weld at the faying surfaces of a joint by the heat obtained from resistance to the flow of welding current through the workpieces from electrodes that serve to concentrate the welding current and pressure at the weld area. See PARAGRAPH 14.9.1.5.

**14.4.59 Resistance Welding (RW).** A group of welding processes that produces coalescence of the faying surfaces with the heat obtained from resistance of the workpieces to the flow of the welding current in a circuit of which the workpieces are a part, and by the application of pressure. See also the Master Chart of Welding and Allied Processes.





- 14.4.60 Root Bead.** A weld deposit that extends into or includes part or all of the root of the joint.
- 14.4.61 Root Crack.** A crack in the weld or heat-affected zone occurring at the root of a weld.
- 14.4.62 Root Face.** That portion of the groove face adjacent to the root of the joint.
- 14.4.63 Root Gap.** See preferred term Root Opening.
- 14.4.64 Root Of Joint.** That portion of a joint to be welded where the members approach closest to each other. In cross section, the root of the joint may be either a point, a line, or an area.
- 14.4.65 Root Of Weld.** The points shown in a cross section, at which the root surface intersects the base metal surfaces. See PARAGRAPH 14.9.2.4.
- 14.4.66 Root Opening.** The separation between the members to be joined at the root of the joint.
- 14.4.67 Root Penetration.** The depth that a weld extends into the root of a joint measured on the centerline of the root cross section.
- 14.4.68 Root Surface.** The exposed surface of a weld on the side other than the one on which welding was done. See PARAGRAPH 14.9.2.4.
- 14.4.69 Scarf Joint.** A form of butt joint. See FIGURE 14-10.
- 14.4.70 Seam Weld.** A continuous weld made between or upon overlapping members, in which coalescence may start and occur on the faying surfaces, or may have proceeded from the surface of one member. The continuous weld may consist of a single weld bead or a series of overlapping spot welds. See PARAGRAPH 14.9.1.6.
- 14.4.71 Size Of Weld.**
- 14.4.71.1 Groove Weld.** The joint penetration (depth of bevel plus the root penetration when specified). The size of a groove weld and its effective throat are one and the same See FIGURE 14-14.
- 14.4.71.2 Fillet Weld.** For equal leg fillet welds size is determined by the leg lengths of the largest isosceles right triangle which can be inscribed within the fillet weld cross section. See FIGURE 14-14.
- NOTE:** When one member makes an angle with the other member greater than 105 degrees, the leg length (size) is of less significance than the effective throat, which is the controlling factor for the strength of a weld.
- 14.4.71.3 Flange Weld.** The weld metal thickness measured at the root of the weld.
- 14.4.72 Slot Weld.** A weld made in an elongated hole in one member of a lap or T-joint joining that member to that portion of the surface of the other member which is exposed through the hole. The hole may be open at one end and may be partially or completely filled with weld metal. (A fillet-welded slot should not be construed as conforming to this definition.) See PARAGRAPH 14.9.1.4.
- 14.4.73 Soldering (S).** A group of welding processes that produces coalescence of materials by heating them to the soldering temperature and by using a filler metal having a liquidus not exceeding 450 °C(840 °F) and below the solidus of the base metals. The filler metal is distributed between closely fitted faying surfaces of the joint by capillary action. See also the Master Chart of Welding and Allied Processes.
- 14.4.74 Solid-State Welding (SSW).** A group of welding processes that produces coalescence by the application of pressure at a welding temperature below the melting temperatures of the base metal and the filler metal.



**14.4.75 Spot Weld.** A weld made between or upon overlapping members in which coalescence may start and occur on the faying surfaces or may proceed from the surface of one member. The weld cross section (plan view) is approximately circular. See PARAGRAPH 14.9.1.5. See also **Resistance Spot Welding**.

**14.4.76 Stringer Bead.** A type of weld bead made without appreciable weaving motion. See also **Weave Bead**. See PARAGRAPH 14.9.1.7.

**14.4.77 Substrate.** Any base material to which a thermal sprayed coating or surfacing weld is applied.

**14.4.78 Surfacing Weld.** A type of weld composed of one or more stringer or weave beads deposited on an unbroken surface to obtain desired properties or dimensions. See PARAGRAPH 14.9.1.7.

**14.4.79 Tack Weld.** A weld made to hold parts of a weldment in proper alignment until the final welds are made.

**14.4.80 Throat Of A Fillet Weld.**

**14.4.80.1 Theoretical Throat.** The distance from the beginning of the root of the joint perpendicular to the hypotenuse of the largest right triangle that can be inscribed within the fillet weld cross section. This dimension is based on the assumption that the root opening is equal to zero.

**14.4.80.2 Actual Throat.** The shortest distance from the root of a weld to its face.

**14.4.80.3 Effective Throat.** The minimum distance minus any reinforcement from the root of a weld to its face.

**14.4.81 Throat Of A Groove Weld.** See preferred term **Size of Weld** (Para 14.4.71)

**14.4.82 T-Joint.** A joint between two members located approximately at right angles to each other in the form of a T. See TABLE 14-2.

**14.4.83 Toe Of Weld.** The junction between the face of a weld and the base metal.

**14.4.84 Upset Welding (UW).** A resistance welding process that produces coalescence over the entire area of faying surfaces or progressively along a butt joint by the heat obtained from the resistance to the flow of welding current through the area where those surfaces are in contact. Pressure is used to complete the weld.

**14.4.85 Weave Bead.** A type of weld bead made with transverse oscillation.

**14.4.86 Weld.** A localized coalescence of metals or nonmetals produced either by heating the materials to suitable temperatures with or without the application of pressure, or by the application of pressure alone, with or without the use of filler material.

**14.4.87 Weld Bead.** A weld deposit resulting from a pass. See Stringer Bead and Weave Bead. See PARAGRAPH 14.9.1.7.

**14.4.88 Welding Process.** A materials joining process which produces coalescence of materials by heating them to suitable temperatures with or without the application of pressure, or by the application of pressure alone with or without the use of filler metal. (See the Master Chart of Welding and Allied Processes.)

**14.4.89 Weldment.** An assembly whose component parts are joined by welding.

**14.4.90 Weld Metal.** The portion of a fusion weld which has been completely melted during welding.



### 14.5 WELDING SYMBOL.

**14.5.1 Standard Location Of Elements Of A Welding Symbol.** The Welding Symbol provides the means of placing complete welding information on drawings. See FIGURE 14-2.

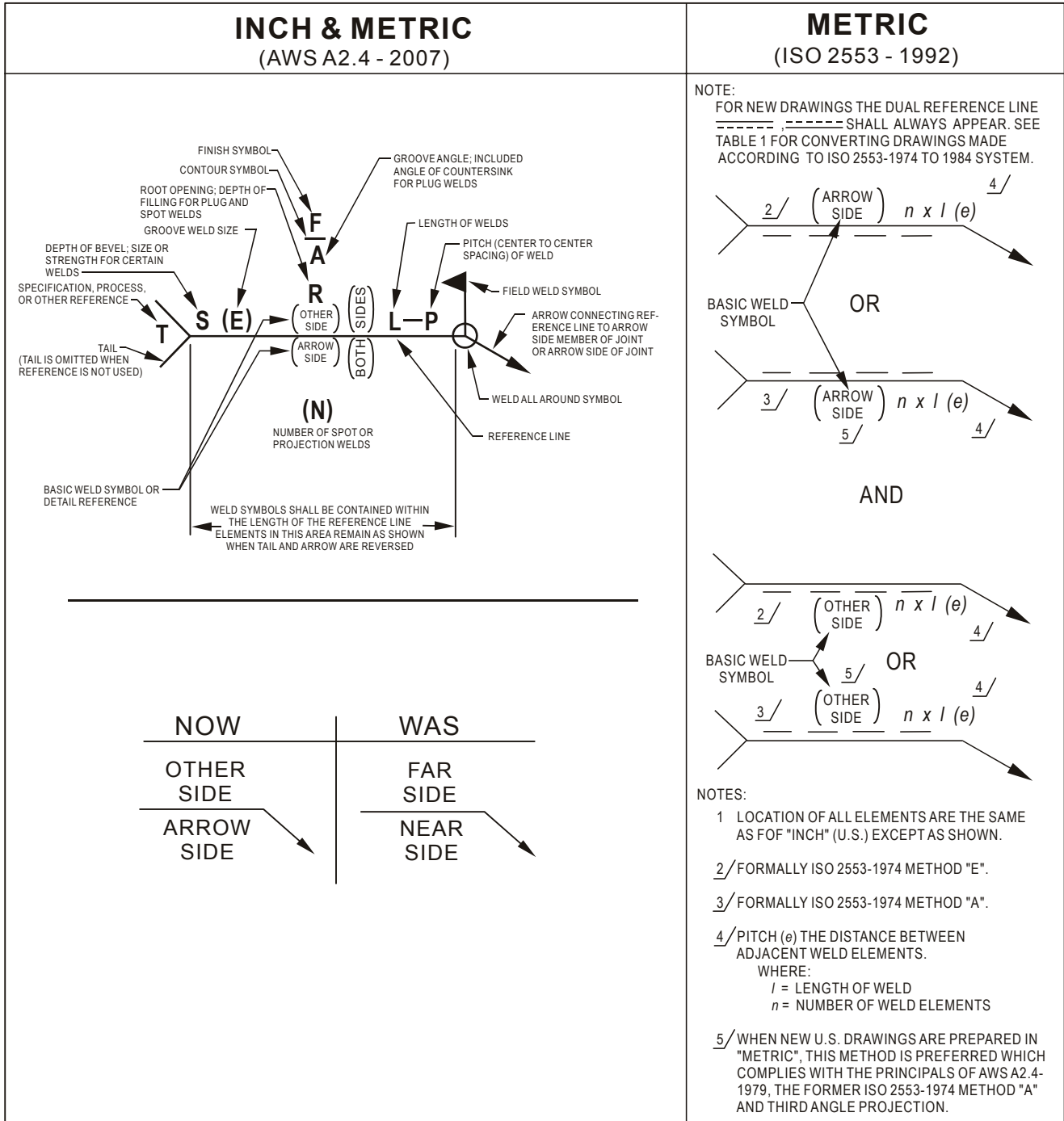

STANDARD LOCATION OF ELEMENTS OF A WELDING SYMBOL.  
FIGURE 14-2



**14.5.2 Standard Size Of A Welding Symbol For Drawing Application.** The Welding Symbol should be consistent in size on any one drawing and should be reasonably close to the sizes shown in FIGURE 14-3. Dimensions for the Welding Symbol are in agreement with Annex C in AWS A2.4-2007. Examples in this section are based on the U.S. inch system. Dimensions on the reference line of the Welding Symbol may be shown in decimal or metric units whichever is applicable.

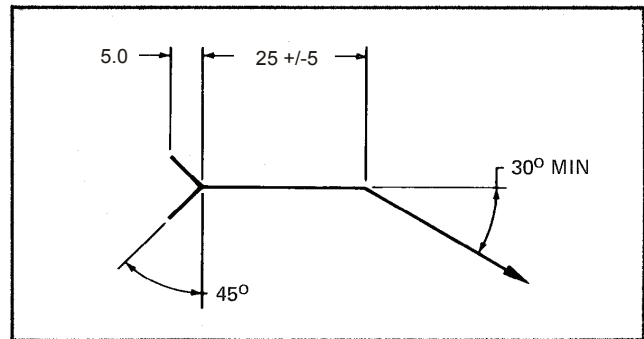
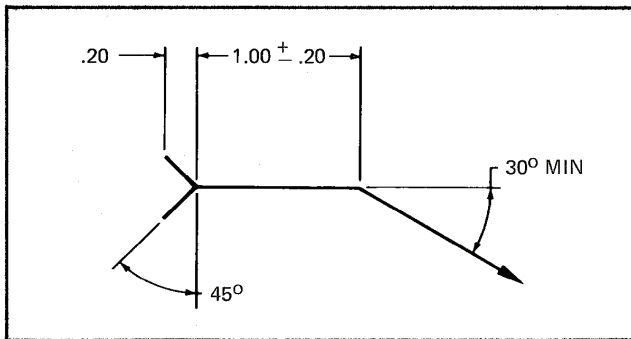

**INCH**  
Symbol Tolerances: +/- .04 & +/- 1°  
As Applicable

**METRIC**  
Symbol Tolerances: +/- 1mm & +/- 1°  
As Applicable

STANDARD SIZE OF A WELDING SYMBOL  
FIGURE 14-3

**14.5.3 Standard Location Of Elements Of The Welding Symbol.** Length, spacing and/or size of welds shall be specified in decimal inch or metric units. Tolerance applied in title block is not applicable to weld callouts, and the decimal or metric unit weld callouts will in no way affect or alter present fabrication and/or inspection procedures. See FIGURE 14-4.

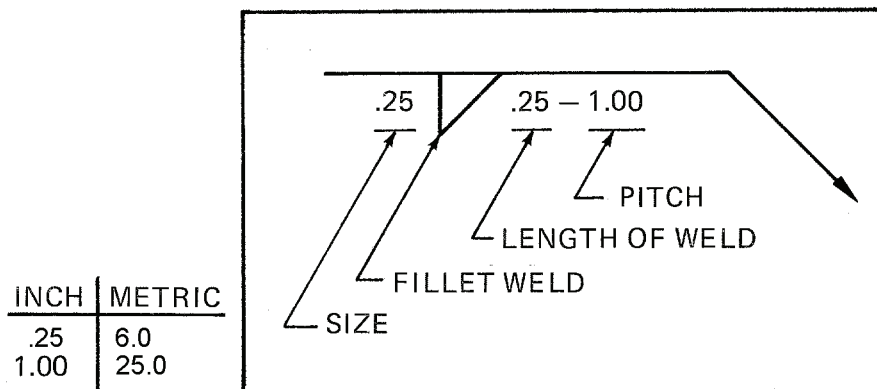

STANDARD LOCATION OF ELEMENTS OF THE WELDING SYMBOL.  
FIGURE 14-4

**14.6 LOCATION SIGNIFICANCE OF THE WELDING SYMBOL ARROW.**

**14.6.1 Indicating Joint For Welding.** Location significance of arrow shall connect the welding symbol reference line to one side of the joint. The terms "Arrow Side", "Other Side" and "Both Sides" are used to locate the weld with respect to the joint. See FIGURE 14-5. The addition of Weld Symbols for the AWS System or the Dashed Reference Line for the ISO System is needed to determine on which side or sides the joint is welded.

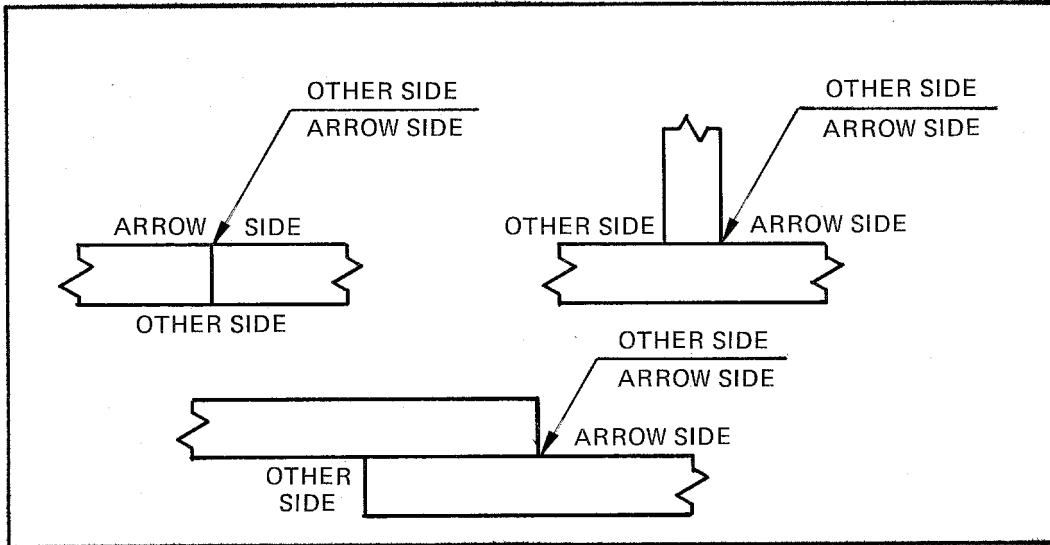

INDICATION OF JOINT FOR WELDING.  
 FIGURE 14-5

**14.6.2 Placement Of Arrow Line.** The arrow line should point to the joint where the weld is located. See FIGURE 14-6. (Both sides (Plates) have identical faces.)

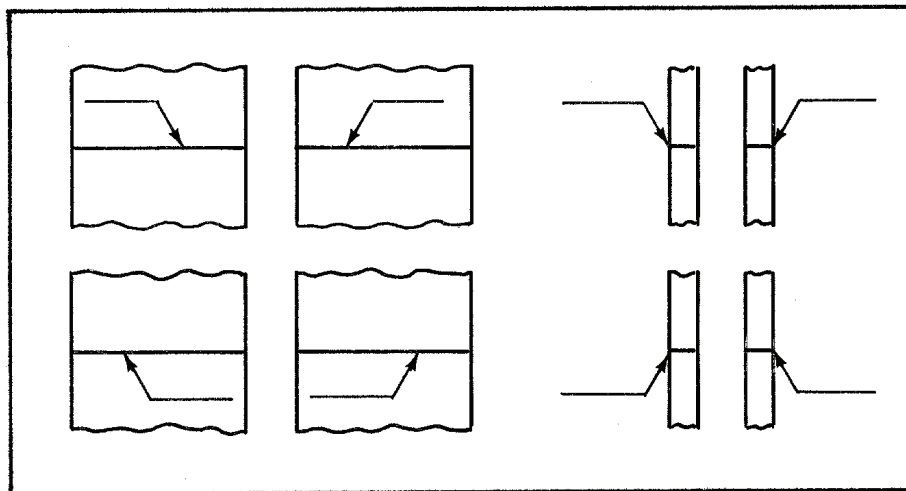

PLACEMENT OF ARROW LINE.  
 FIGURE 14-6

**14.6.3 Placement Of Arrow Line For Joint Preparation.** Whenever one side (plate) is specifically prepared for the welded joint, then an arrow with a broken leader shall point to the side (plate) which is to be prepared. See FIGURE 14-7.

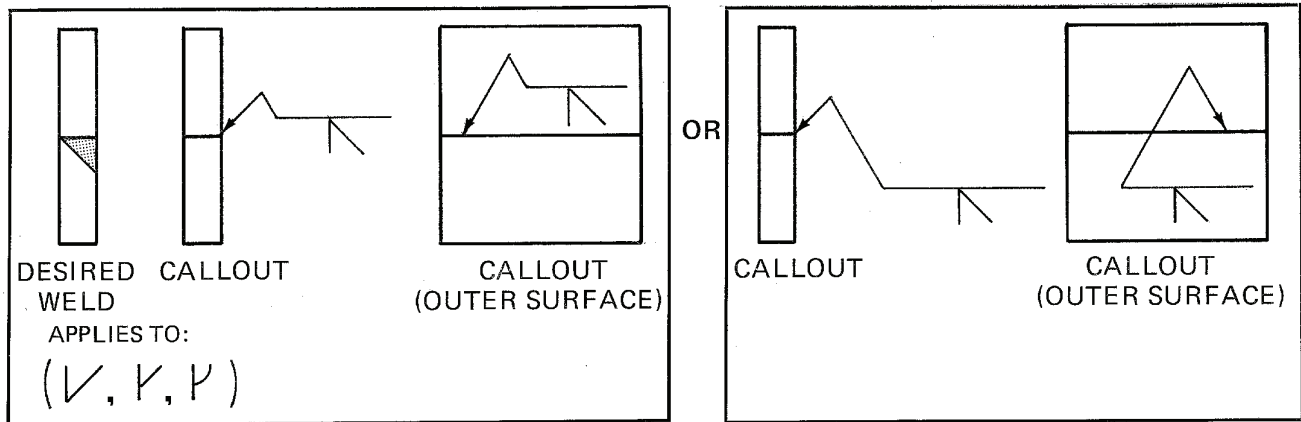

PLACEMENT OF ARROW LINE FOR JOINT PREPARATION.  
 FIGURE 14-7

**14.6.4 Placement Of Arrow Line For Joining Surfaces With Significant Sides.**

Whenever the weld is made within the plane of the joint as is the case with **Plug, Slot, Spot, Seam** and **Projection** welds, the arrow line shall point to the outer surface of one of the members of the joint at the centerline of the desired weld. The member toward which the arrow points shall be considered the "arrow side" member. The other member of the joint shall be considered the "other side" member. See FIGURE 14-8.

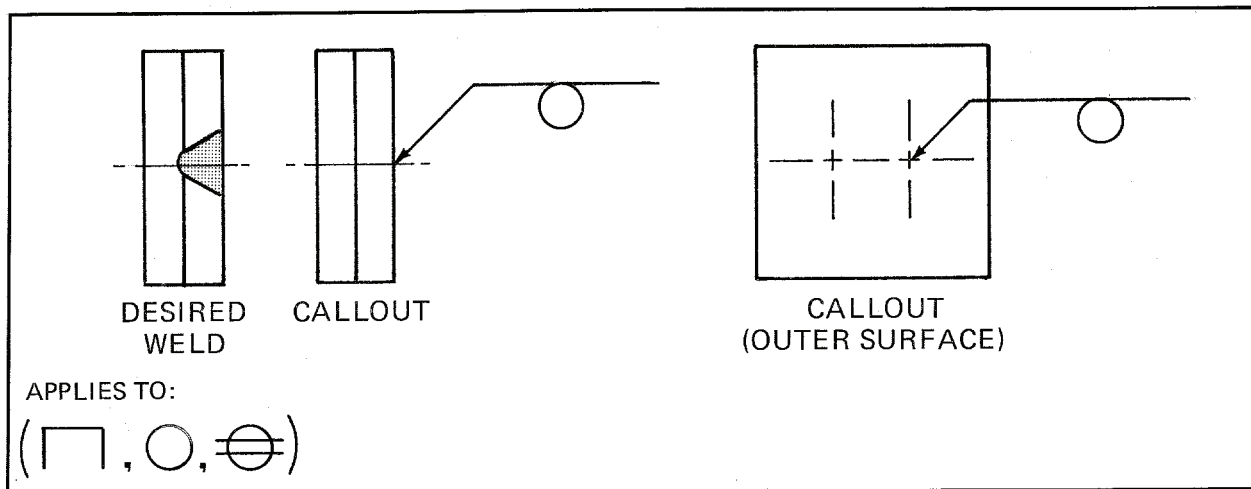

PLACEMENT OF ARROW LINE FOR JOINING SURFACES  
WITH SIGNIFICANT SIDES.  
 FIGURE 14-8



**14.6.5 Placement Of Arrow Line For Joining Surfaces With No Side Significance.**

Whenever a weld is made in which neither side has any significance or preparing requirements, the arrow line points to the joint or surface and the weld symbol is centrally located on either side of the Welding Symbol reference line. See FIGURE 14-9.

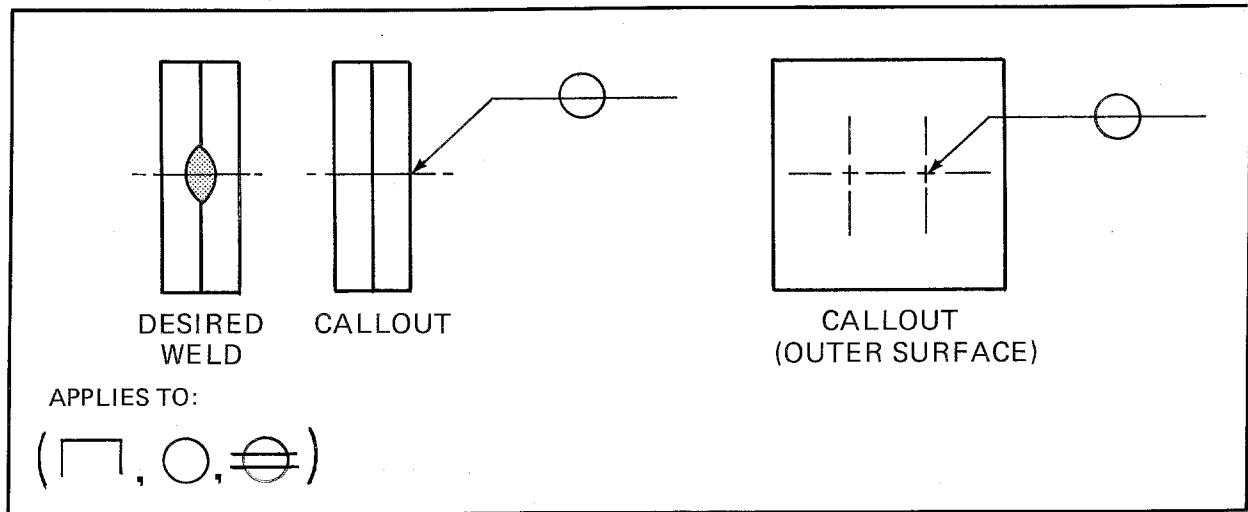

PLACEMENT OF ARROW LINE FOR JOINING SURFACES  
WITH NO SIDE SIGNIFICANCE.  
FIGURE 14-9

**14.6.6 Position Of The Weld Symbol With Regard To The Welding Symbol Reference Line.** The position of the Weld Symbol is defined by two different standards. AWS A2.4 -2007 (also 1998) covers INCH and METRIC and ISO 2553-1992 covers METRIC. The standard invoked or referenced by the drawing determines which standard and which method applies. See FIGURE 14-2.

- a. AWS A2.4-2007:

Placement of the WELD SYMBOL governs which side of the joint is to be welded for drawings prepared in accordance with AWS A2.4-2007.

- b. ISO 2553-1992:

Placement of the WELD SYMBOL with regards to the CONTINUOUS or DASHED REFERENCE LINE governs which side of the joint is to be welded for drawings prepared in accordance with ISO 2553-1992.

ALL ILLUSTRATIONS, unless otherwise specified, in this section are shown in THIRD ANGLE PROJECTION for either "INCH" or "METRIC" drawings. The following illustrations conform to AWS A2.4 unless otherwise specified.

- i.e.

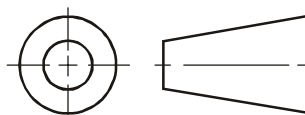

**14.7 WELD SYMBOLS.**

**14.7.1 Basic Weld Symbols.** Weld symbols are ideographs used to indicate the desired type of weld. See FIGURE 14-10.

		GROOVE							
SYSTEM		SQUARE	<sup>1/</sup> SCARF	V	BEVEL	U	J	FLARE	FLARE-BEVEL
<b>I N C H</b>	ARROW SIDE								
	OTHER SIDE								
<b>M E T R I C</b>	ARROW SIDE	<sup>2/</sup>	<sup>2/</sup>	<sup>2/</sup>	<sup>2/</sup>	<sup>2/</sup>	<sup>2/</sup>	<sup>2/</sup>	<sup>2/</sup>
		OR	OR	OR	OR	OR	OR	OR	OR
	OTHER SIDE	<sup>2/</sup>	<sup>2/</sup>	<sup>2/</sup>	<sup>2/</sup>	<sup>2/</sup>	<sup>2/</sup>	<sup>2/</sup>	<sup>2/</sup>
		OR	OR	OR	OR	OR	OR	OR	OR

BASIC WELD SYMBOLS.  
 FIGURE 14-10

SYSTEM	FILLET	PLUG OR SLOT	STUD	SPOT OR PROJECTION	SEAM	BACK OR BACKING	SURFACING	EDGE AND CORNER
<b>I N C H</b>	ARROW SIDE							
	OTHER SIDE							
<b>M E T R I C</b>	ARROW SIDE	<sup>2/</sup>	<sup>2/</sup>		<sup>2/</sup>	<sup>2/</sup>		
		OR	OR		OR	OR	OR	OR
	OTHER SIDE	<sup>2/</sup>	<sup>2/</sup>		<sup>2/</sup>	<sup>2/</sup>		
		OR	OR		OR	OR	OR	OR

<sup>1/</sup> USED FOR BRAZED JOINTS ONLY.  
<sup>2/</sup> PREFERRED ON U.S. DRAWINGS THAT USE METRIC DIMENSIONS.

BASIC WELD SYMBOLS.  
 FIGURE 14-10 (Continued)



**14.7.2 Supplementary Weld Symbols.** Used in connection with basic weld symbols.

SUPPLEMENTARY SYMBOLS							
WELD-ALL-AROUND	FIELD WELD	MELT-THRU	CONSUMABLE INSERT (SQUARE)	BACKING OR SPACER (RECTANGLE)	CONTOUR		
					FLUSH	CONVEX	CONCAVE

\* IF BACKING IS TO BE REMOVED AFTER WELDING, INSERT THE LETTER "R".  
SUPPLEMENTARY WELD SYMBOLS.

FIGURE 14-11

**14.7.3 Obsolete Weld Symbols.** Not to be used for new design (see Figure 14-12). Use preferred symbol with process reference placed in the tail. See FIGURE 14-2.

TYPE OF WELD						
PLUG OR SPOT	ARC SPOT OR ARC SEAM	RESISTANCE SPOT	PROJECTION	RESISTANCE SEAM	FLASH OR UPSET	FIELD

OBSELETE SYMBOLS.

FIGURE 14-12

**14.7.4 Contours Obtained by Finish Symbols.** Finish symbols may be used to indicate the method of finishing as flush, flat, convex or concave but not the degree of finish. The method, when specified, shall be indicated by adding the appropriate contour symbol and finish symbol. See FIGURE 14-2 for location of the Contour Finish Symbol on the Welding Symbol. The basic finish symbols are:

EXAMPLES

C = Chipping  
M = Machining  
G = Grinding  
R = Rolling  
H = Hammering

**14.8 BASIC SIZE OF WELD SYMBOLS.**

**14.8.1 Size Of The Weld Symbol.** The size of WELD SYMBOL should be consistent in size on any one drawing and should be reasonably close to the sizes shown in FIGURE 14-13A and 13B Dimensions are to be used to draw a Weld Symbol and are in agreement with standard templates. The examples used in this section are in the "INCH" (U.S.) system. Dimensions may be in inches or metric, whichever is applicable.

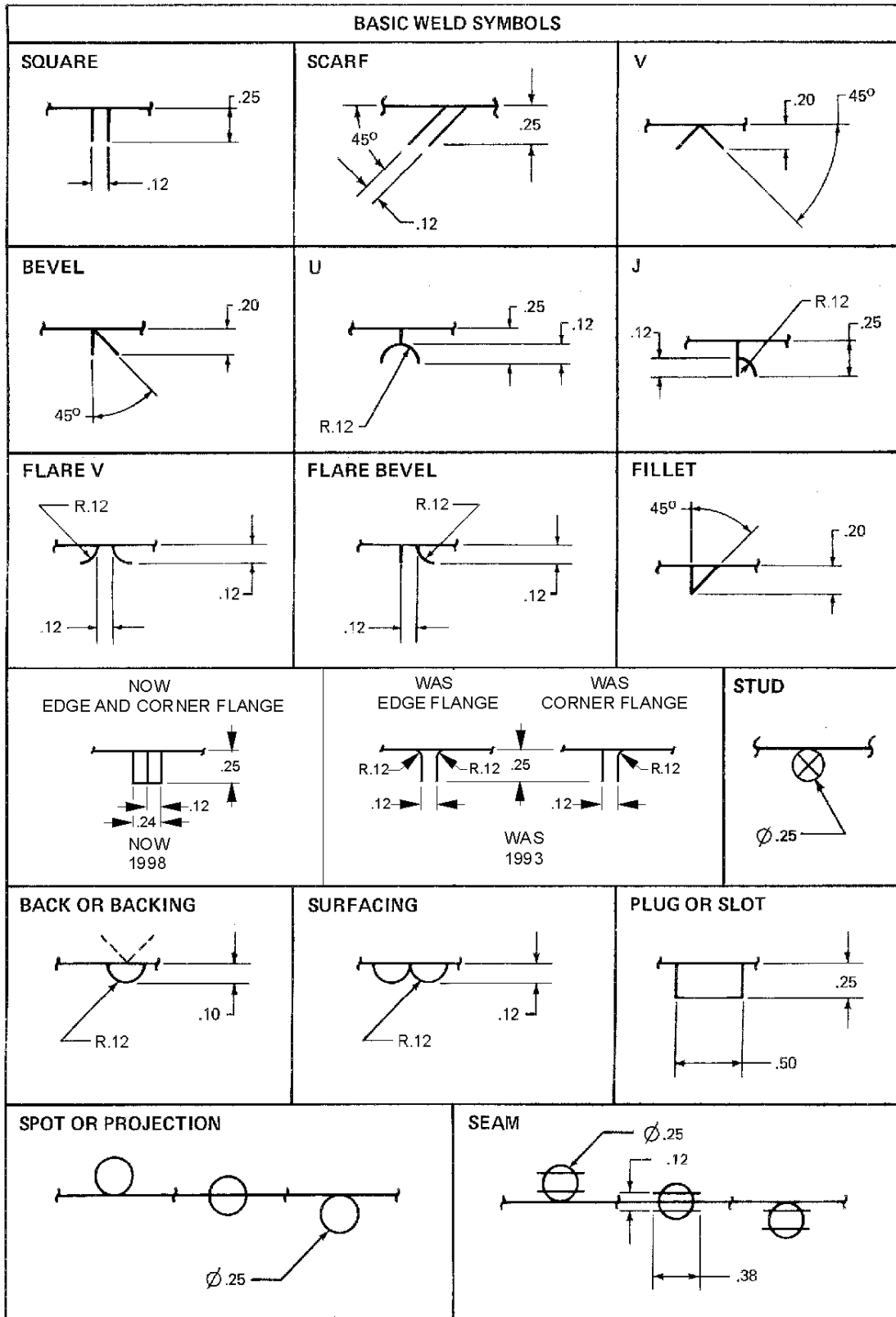

DESIGN AND DIMENSIONS FOR BASIC "WELD SYMBOLS".

FIGURE 14-13A

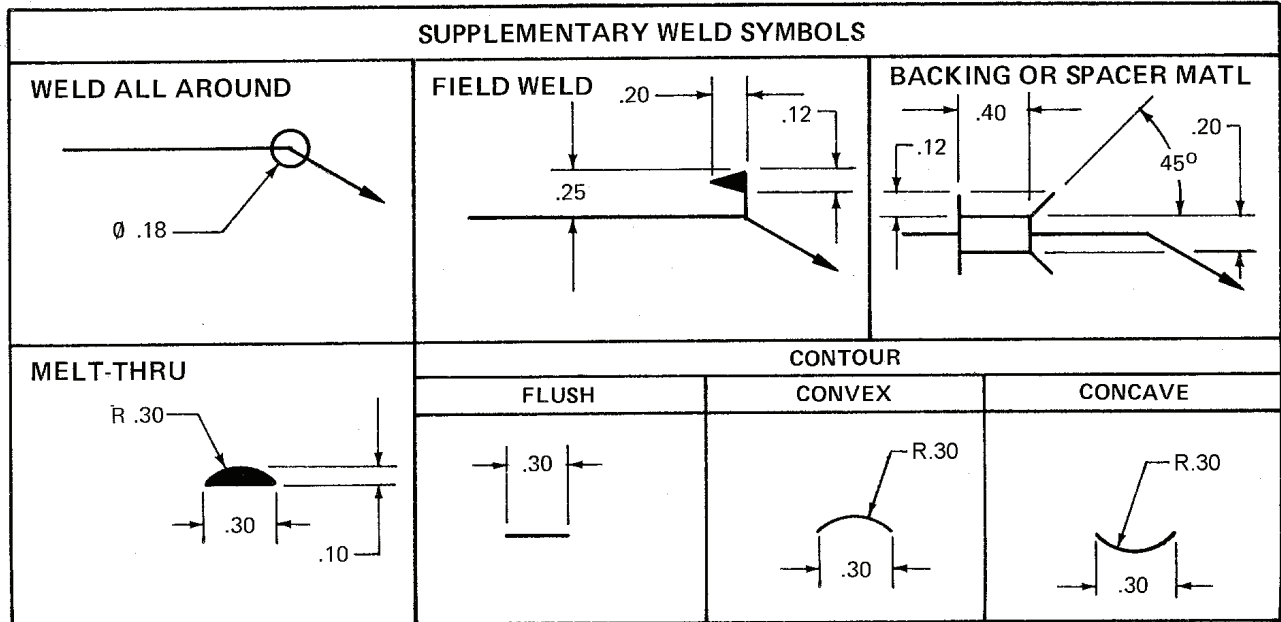

**NOTES:**

1. UNLESS OTHERWISE SPECIFIED, TOLERANCE SHALL BE  $\pm .04$  or  $\pm 1^\circ$  AS APPLICABLE.
2. ALL RADII ARE MINIMUM DIMENSIONS.
3. ALL ILLUSTRATIONS ARE "ARROW SIDE" SIGNIFICANCE UNLESS OTHERWISE SHOWN.

INCH	* METRIC
.04	1.0
.10	2.5
.12	3.0
.18	4.5
.20	5.0
.25	6.0
.30	7.5
.38	9.0
.40	10.0
.50	12.0

\*Dimensions in millimeters are in whole and half numbers and are not inch to millimeter conversions.

DESIGN AND DIMENSIONS FOR SUPPLEMENTARY "WELD SYMBOLS.  
FIGURE 14-13B



### 14.9 BASIC TYPES OF WELDS.

**14.9.1 Common Welds.** There are eight (8) basic welds, classified as common welds, employed in welded joints.

#### BASIC WELD

#### SYMBOLOGY

**14.9.1.1 Groove Weld.** (Single and Double) - A weld made in the groove between two members to be joined.

#### BASIC WELD NO. 1 (Groove)

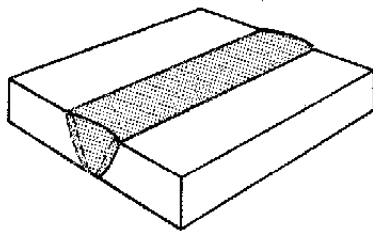

SINGLE V-GROOVE WELD

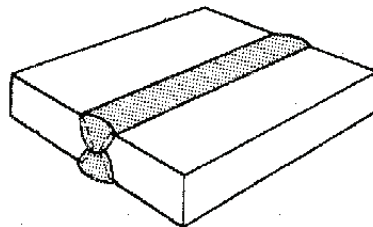

DOUBLE V-GROOVE WELD

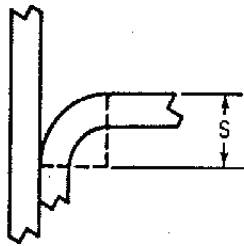

FLARE-BEVEL-GROOVE

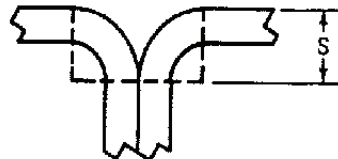

FLARE-V-GROOVE

S = RADIUS FROM  
POINT OF TAN-  
GENCY TO TOP  
OF MEMBER

#### SYMBOLS THAT APPLY TO GROOVE WELDS

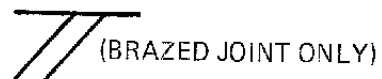
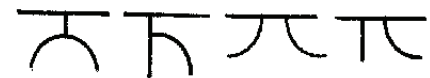
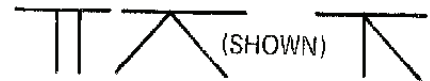

Note: Flare Groove Welds. Flare groove welds extend only to the tangent points, as indicated below by dimension lines. The extension beyond the point of tangency is treated as an edge or lap joint.



**BASIC WELD**

**SYMBOLOGY**

**14.9.1.2 Flange Weld.** A weld made on the edges of two or more members joined. Usually light gauge metals are joined with at least one or more of the members being flanged.

BASIC WELD NO. 2 (Flange)

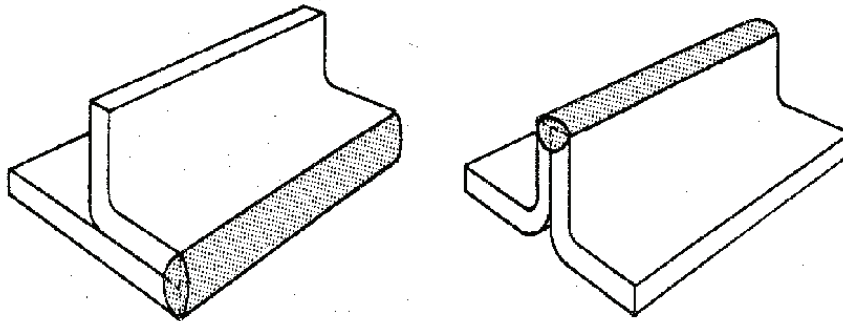

EDGE AND CORNER FLANGE WELD

SYMBOL THAT APPLY TO FLANGE WELDS

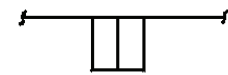

EDGE

**14.9.1.3 Fillet Weld.** A weld of approximately triangular cross section joining two surfaces approximately at right angles to each other in a lap joint, T-joint or corner joint.

BASIC WELD NO. 3 (Fillet)

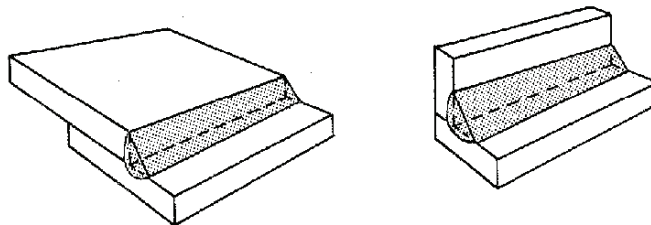

LAP JOINT

CORNER JOINT

SYMBOL THAT APPLY TO FILLET WELDS

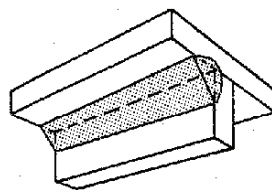
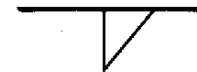

T - JOINT



**BASIC WELD**

**SYMBOLOGY**

**14.9.1.4 Plug Weld.** A circular weld made through a hole in one member of a Lap Joint or T-joint fusing that member to the other. The walls of the hole may or may not be parallel and the hole may be partially or completely filled with weld material.

BASIC WELD NO. 4 (Plug)

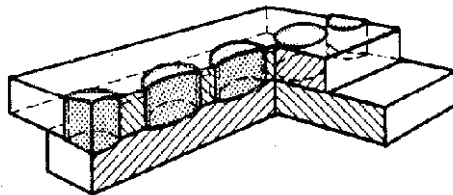

PLUG WELD

AND

SYMBOL THAT APPLY  
TO PLUG WELDS

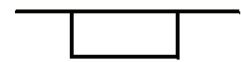

**Slot Weld.** A weld made in an elongated hole in one member of a lap or T-joint joining that member to that portion of the surface of the other member which is exposed through the hole. The hole may be open at one end and may be partially or completely filled with weld metal.

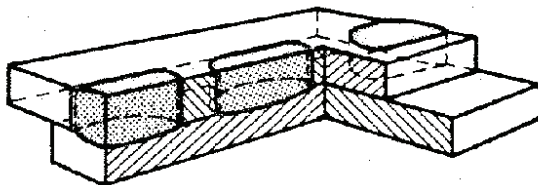

PLUG WELD

SYMBOL THAT APPLY  
TO SLOT WELDS



NOTE: SIZE & SPACING OF SLOTS SHALL  
BE SHOWN ON THE DRAWING WHEN  
NOT INCLUDED WITH THE SYMBOL



**BASIC WELD**

**SYMBOLOGY**

**14.9.1.5 Spot Weld.** A weld made between or upon overlapping members in which coalescence may start and occur on the faying surfaces or may proceed from the surface of one member. The weld cross section (plan view) is approximately circular. Also applies to **Spot** and **Resistance Spot Welding**.

BASIC WELD NO. 5 (Spot)

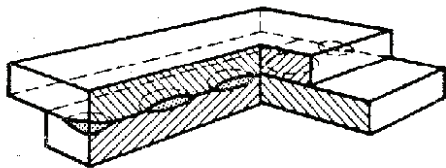

RESISTANCE SPOT WELD

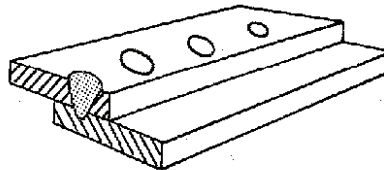

ARC SPOT WELD

SYMBOL THAT APPLY TO SPOT WELDS



ARC



RESISTANCE

**14.9.1.6 Seam Weld.** A continuous weld made between or upon overlapping members in which coalescence may start and occur on the faying surfaces or may have proceeded from the surface of one member. The continuous weld may consist of a single weld bead or a series of overlapping **Spot Welds**.

BASIC WELD NO. 6 (Seam)

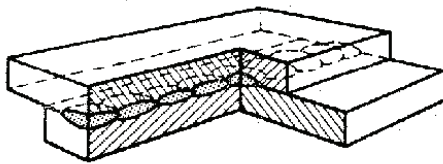

RESISTANCE SEAM WELD

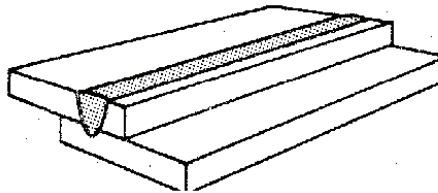

ARC SEAM WELD

SYMBOL THAT APPLY TO SEAM WELDS



ARC



RESISTANCE

**14.9.1.7 Surfacing Weld.** A type of weld composed of one or more stringer or weaver beads deposited on an unbroken surface to obtain desired properties or dimensions.

BASIC WELD NO. 7 (Surfacing)

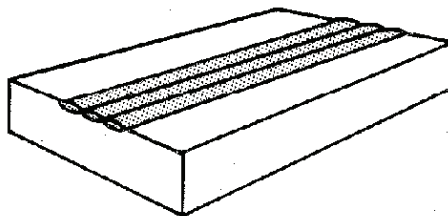

SURFACING WELD

SYMBOL THAT APPLY TO SURFACING WELDS





**BASIC WELD**

**SYMBOLOGY**

14.9.1.8 **Back Weld.** A weld deposited at the back of a single groove weld.

BASIC WELD NO.8 (Back)

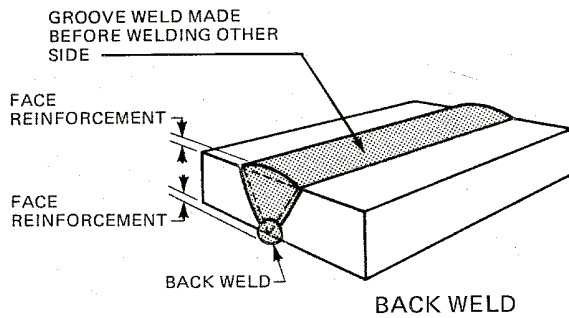

AND

Backing Weld - Backing in the form of a weld.

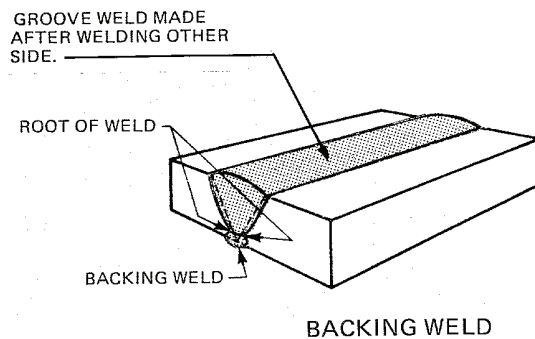

SYMBOL THAT APPLIES TO BACK WELD



SYMBOL THAT APPLIES TO BACKING WELD



**SUPPLEMENTAL WELD**

**SYMBOLOGY**

14.9.2 **Supplementary Weld Symbols.** Symbols to be used in connection with basic weld symbols.

14.9.2.1 **Weld All Around.** Welds extending completely around a joint.

**SI**

For Example:

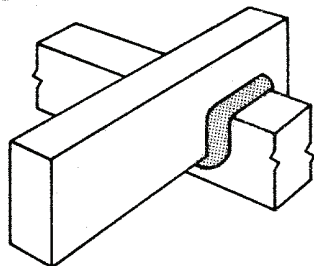

SYMBOL THAT APPLIES TO ALL AROUND WELD

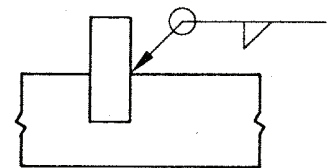





**SUPPLEMENTAL WELD**

**SYMBOLOGY**

**14.9.2.2 Stud Weld.** Stud weld does not indicate the welding of joint in the ordinary sense and, therefore, has no arrow-or other-side significance.

For Example:

INCH	METRIC
.50	13.0
.75	19.0
1.00	25.0

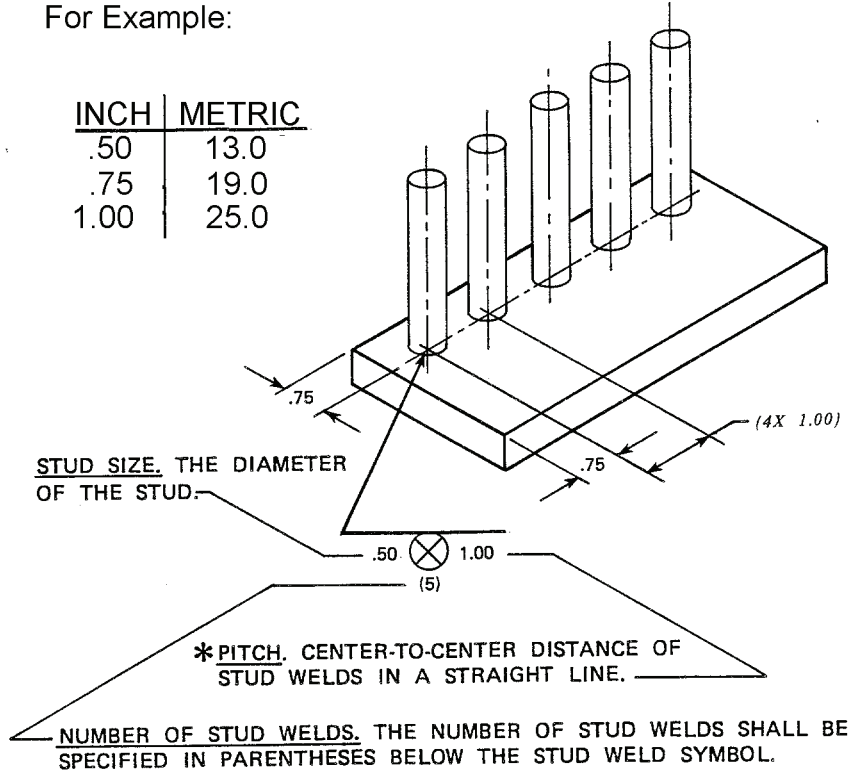

SYMBOL THAT APPLIES TO STUD WELD

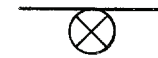

\* THE SPACING OF STUD WELDS IN ANY CONFIGURATION OTHER THAN A STRAIGHT LINE SHALL BE DIMENSIONED ON THE DRAWING.

NOTE:

A STUD WELD IS NOT A JOINT WELD IN THE ORDINARY SENSE AND "ARROW SIDE" OR "OTHER SIDE" HAS NO SIGNIFICANCE. THE SYMBOL SHALL BE PLACED BELOW THE REFERENCE LINE AND THE ARROW SHALL POINT TO THE SURFACE TO WHICH THE STUD IS TO BE WELDED.

**14.9.2.3 Field Weld.** Field welds are welds that are made at a place other than that of initial construction.

For Example:

**ALL APPLICABLE WELDS**

SYMBOL THAT APPLIES TO FIELD WELD





**SUPPLEMENTAL WELD**

**SYMBOLOGY**

**14.9.2.4 Melt-Thru.** Complete joint penetration for a joint welded from one side. Visible root reinforcement is produced.

For Example:

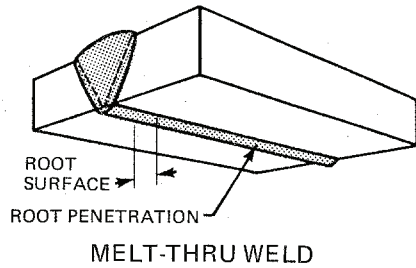

SYMBOL THAT APPLIES TO MELT-THRU WELD



ALSO APPLIES TO:

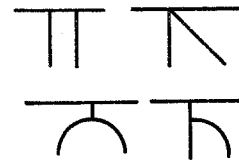

**14.9.2.5 Backing Or Spacer Material.** A material placed at the root of a weld joint for the purpose of supporting molten weld metal. A spacer bar prepared for a groove weld and inserted in the root of a joint to serve as a backing to maintain root opening during welding. Suitable notation and explanation shall be provided within the rectangle and tail to identify materials and dimensions.

For Example:

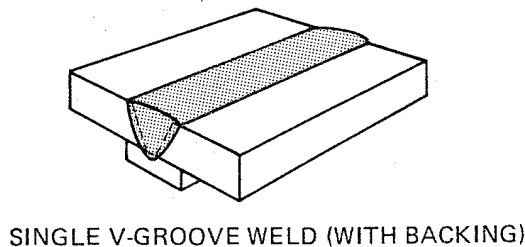

SYMBOLS & NOTE THAT APPLY TO WELDS WITH BACKING MATERIAL ADDED

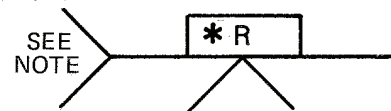

\* IF BACKING IS TO BE REMOVED AFTER WELDING, INSERT THE LETTER "R".

ALSO APPLIES TO:

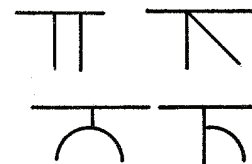

NOTE: MATERIAL & DIMENSIONS OF BACKING AS SPECIFIED



**SUPPLEMENTAL WELD**

**SYMBOLOGY**

**14.9.2.6 Contour (Natural).** Contours obtained by welding are to be approximately flat, convex, or concave without recourse to any method of finishing, and shall be shown by adding the flush, convex or concave symbol to the Weld Symbol in accordance with the location conventions shown in FIGURE 14-2.

For Example:

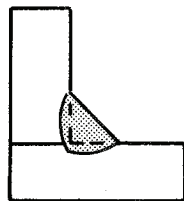

FLUSH

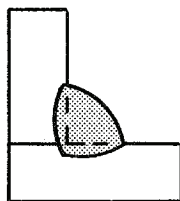

CONVEX

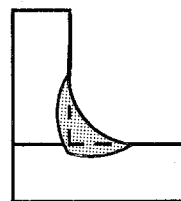

CONCAVE

MOST WELD SYMBOLS CAN BE USED WITH CONTOUR WELDS

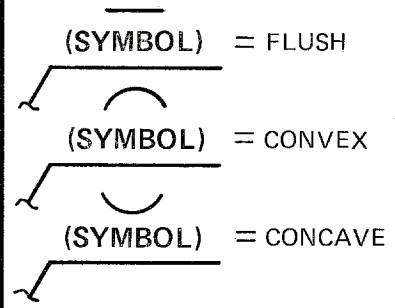

**14.9.2.7 Contours (Mechanical Means).** Contours which are obtained by mechanical means shall be shown by adding the mechanical method to the contour symbol in accordance with the location convention shown in FIGURE 14-2. The mechanical methods used are defined in PARAGRAPH 14.7.4.

For Example:

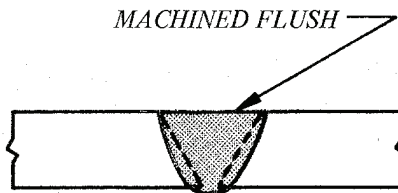

FLUSH WELD BY MECHANICAL MEANS

GENERALLY ALL WELD SYMBOLS CAN BE USED WITH WELD CONTOURS THAT ARE ACHIEVED BY MECHANICAL MEANS.

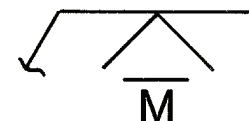

V-GROOVE WELD SHOWN IS MADE FLUSH BY MACHINING

**14.10 DIMENSIONING OF WELDS.**

**14.10.1 General Rules.** These dimensions are governed by their appearance in accordance with their location convention shown in FIGURE 14-2.

**14.10.1.1 Dimensioning Cross Section Of The Weld.** The dimension relative to the cross section of the weld is shown on the left hand side (before) of the symbol. See FIGURE 14-14.

**14.10.1.2 Dimensioning Length/Pitch Of The Weld.** The dimension relative to longitudinal (length, pitch) of the weld is shown on the right hand side (after) of the symbol. See FIGURE 14-14.



INCH & METRIC (AWS A2.4-2007)		METRIC (ISO 2553-1992)	
$S \text{ (SYM)} \text{ L-P}$ 		$S \text{ (SYM)} \text{ } n \times l \text{ (e)}$ 	
<p>S = DEPTH OF PREPARATION L = LENGTH OF WELD P = PITCH (CENTER-TO-CENTER) SPACING OF WELD</p>		<p>S = DEPTH OF PREPARATION l = LENGTH OF WELD n = NUMBER OF WELD ELEMENTS e = PITCH (DISTANCE BETWEEN WELD ELEMENTS AND CENTER-TO-CENTER FOR SPOT WELDS)</p>	
<p>ILLUSTRATION</p>	<p><b>GROOVE WELD</b></p> <p>S = MINIMUM DISTANCE FROM THE SURFACE OF THE PART TO THE BOTTOM OF THE PENETRATION, WHICH CANNOT BE GREATER THAN THE THICKNESS OF THE THINNER PART.</p>	<p>SYMBOL</p>	
<p>ILLUSTRATION</p>	<p><b>GROOVE WELD (BETWEEN FLANGED MEMBERS)</b></p> <p>S = MINIMUM DISTANCE FROM THE EXTERNAL SURFACE OF THE WELD TO THE BOTTOM OF THE PENETRATION.</p>	<p>SYMBOL</p>	
<p>ILLUSTRATION</p> <p>Z<sub>1</sub> = HEIGHT Z<sub>2</sub> = LENGTH</p>	<p><b>CONTINUOUS FILLET WELD</b></p> <p>SYMBOL</p> <p>S = Z (EQUAL LEGS) S = (Z<sub>1</sub> X Z<sub>2</sub>) (UNEQUAL LEGS)</p>	<p>ILLUSTRATION</p>	<p>SYMBOL</p>
<p>ILLUSTRATION</p>	<p><b>INTERMITTENT FILLET WELD</b></p> <p>SYMBOL</p> <p>L-P</p>	<p>ILLUSTRATION</p>	<p>SYMBOL</p>

DIMENSIONING OF WELDS.  
FIGURE 14-14 (Continued next page.)



FIGURE 14-14 (Continued)

- 1/ IN THE ABSENCE OF ANY INDICATION FOLLOWING THE WELD SYMBOL MEANS THAT THE WELD IS CONTINUOUS OVER THE WHOLE LENGTH OF THE WORKPIECE.
- 2/ IN THE ABSENCE OF ANY INDICATION TO THE CONTRARY, GROOVE WELDS ARE TO HAVE COMPLETE PENETRATION (MELT-THRU)
- 3/ GROOVE WELDS BETWEEN PLATES WITH RAISED EDGES NOT COMPLETELY PENETRATED SHALL HAVE THE WELD THICKNESS SHOWN.
- 4/ FOR FILLET WELDS, THERE ARE TWO (2) METHODS TO INDICATE DIMENSIONS AS EITHER "a" OR "z". THE DIMENSIONS "a" OR "z" SHALL BE PLACED IN FRONT OF THE VALUE OF THE FILLET WELD DIMENSION.

DIMENSIONING OF WELDS.

FIGURE 14-14 (Continued from previous page.)

14.11 STANDARD EDGE PREPARATIONS.

DESIRED WELD

SYMBOLOGY

14.11.1 Weld Thickness Range. Thickness range from .005 to .125 inclusive. See FIGURE 14-15.

INCH	METRIC
.005	0.13
.125	3.18

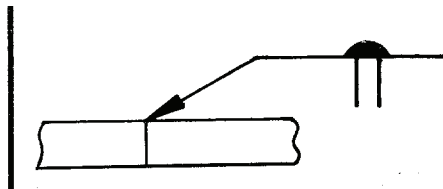
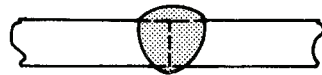

WELD THICKNESS RANGE .005 THRU .125.

FIGURE 14-15

14.11.2 Weld Thickness Range From One Side Only. Thickness range from .060 thru .250 when it is desirable or necessary to weld from one side. See FIGURE 14-16.

INCH	METRIC
.05	1.3
.060	1.52
.20	5.1
.25	6.4
.375	9.52

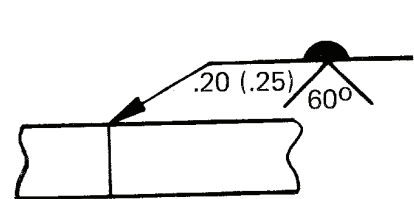
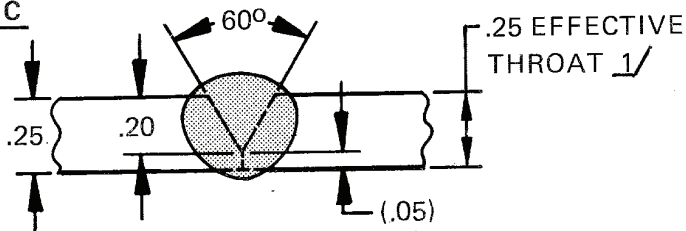

- 1/ TOTAL EFFECTIVE WELD THROAT THICKNESS CANNOT BE GREATER THAN THE PLATE THICKNESS.

WELD PREPARATION FOR THICKNESS RANGE .060 THRU .250.

FIGURE 14-16



DESIRED WELD

SYMBOLOGY

**14.11.3 Weld Thickness Range From Both Sides.** Thickness range from .060 thru .375 where both sides of the joint are accessible for welding. See FIGURE 14-17a. It should be noted that for the heavier gauges, an equal, double-side preparation is preferred to minimize distortion of base material by dictating effective throat "E". See FIGURE 14-17b.

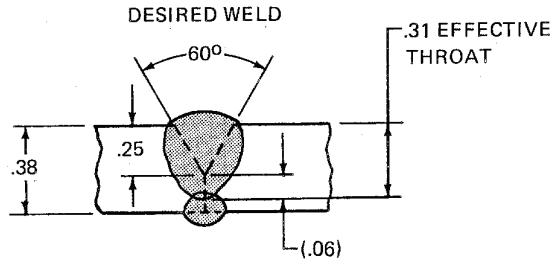

a. WELD PREPARATION FOR THICKNESS RANGE .060 THRU .375

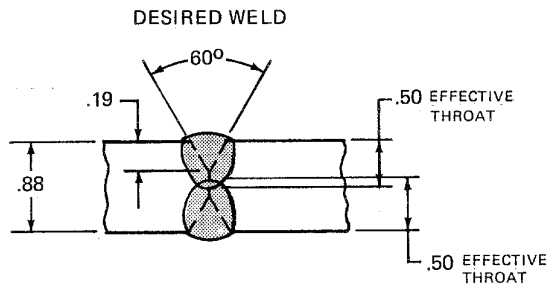

b. WELD PREPARATION FOR HEAVIER GAGES

INCH	METRIC
.06	1.5
.19	4.8
.25	6.4
.31	7.9
.38	9.6
.50	12.7
.88	22.4

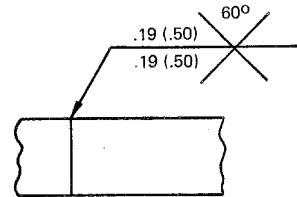
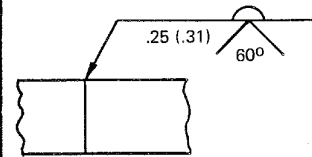

WELD THICKNESS RANGE AS DETERMINED BY ENGINEERING AND THE APPLICATION.  
FIGURE 14-17



**14.12 WELDED ASSEMBLIES.** When a weld assembly is shown on a next assembly, the welding is normally not shown again; the unit is now a solid part and should be treated as such. See FIGURE 14-18.

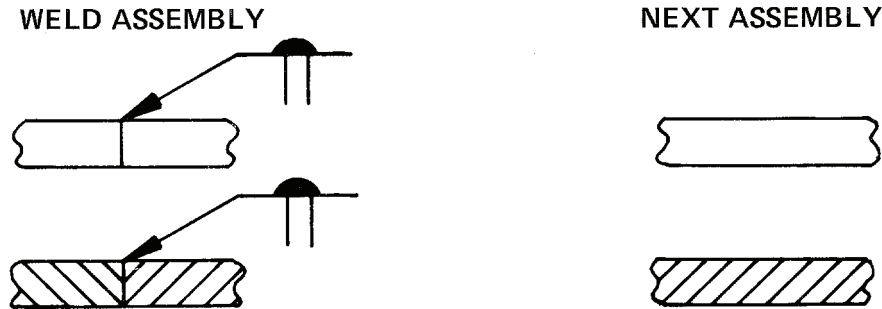

WELDED ASSEMBLIES  
 FIGURE 14-18

**14.13 SUGGESTED WELD ROD CALLOUTS.**

**14.13.1 Weld Information Location.** Information relative to welding processes (See FIGURE 14-19) and weld rod callouts should be incorporated in the notes and parts list (where applicable).

**14.13.2 Weld Rod Material Callout.** Call weld rod material out in Parts List. (PL) See DRM Section 10 herein.

**14.13.3 Placement Of Specification, Process, or Reference With A Welding Symbol.** When a specification, process or other reference is used with a welding symbol, the reference may be placed in the tail.

For example:

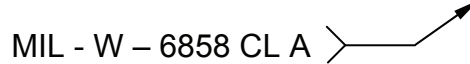

**14.13.4 Use Of Definite Process By Letter Designations.** When use of a definite process is required, the process may be indicated by one or more of the letter designations shown in FIGURE 14-20.

For example:



**14.14 TYPICAL DRAWING NOTES.**

- a. UNLESS OTHERWISE SPECIFIED, ALL FILLET WELDS (weld size dimension)
- b. FUSION WELD PER (applicable specification).
- c. RESISTANCE WELD PER (applicable specification).

**14.15 BASIC TYPES OF JOINTS WITH APPLICABLE WELDS AND APPROPRIATE WELD SYMBOLS.**

**14.15.1 Basic Joints And Common Welds.** The basic types of joints and common welds employed to join them are shown in TABLE 14-2.



TYPE OF WELD JOINT	DRAWING REPRESENTATION						DESIRED WELD
	ILLUSTRATION OF APPLICABLE WELDS	SYMBOLIZATION (ARROW [near] SIDE OF JOINT) REFER TO PARA 14.3 & TABLE 1 FOR 'OTHER SIDE'		POSITION OF ARROW LINE			
		INCH & METRIC (AWS A2.4-2007)	METRIC (ISO 2553-1992)	US	ISO		
<b>BUTT JOINT</b> 	SINGLE FLARE VEE 			2/ 	2/ 	RAISED EDGES MELTED DOWN COMPLETELY 	
	SINGLE FLARE VEE GROOVE 			2/ 	2/ 		
	SINGLE FLARE VEE GROOVE 			2/ 	2/ 		
	EDGE FLANGE 			2/ 	2/ 		
	SQUARE GROOVE (BUTT) 			3/ 	3/ 		
	SINGLE V-GROOVE 						
	SINGLE V-GROOVE WITH BROAD ROOT FACE 						
	SINGLE BEVEL-GROOVE 			3/ 	3/ 		
	SINGLE BEVEL-GROOVE WITH BROAD ROOT FACE 			EITHER 	EITHER 		
	SINGLE U-GROOVE (PARALLEL OR SLOPING SIDES) 			3/ 	3/ 		

Continued On Next Page

**BASIC TYPES OF JOINTS, WELDS AND WELD SYMBOLS.**  
 TABLE 14-2 (Continued next page.)



TYPE OF WELD JOINT	TABLE 2 (Continued)						DESIRED WELD
	ILLUSTRATION OF APPLICABLE WELDS	SYMBOLIZATION (ARROW [near] SIDE OF JOINT) REFER TO PARA 14.3 & TABLE 1 FOR 'OTHER SIDE'		POSITION OF ARROW LINE			
		INCH & METRIC (AWS A2.4-2007)	METRIC (ISO 2553-1992)	US	ISO		
Continued BUTT JOINT	SINGLE J-GROOVE 						
BACKING RUN APPLIED TO ANY SINGLE-GROOVE WELD	BACK OR BACKING 	SEE NOTE  GROOVE WELD MADE FIRST OR BACK WELD MADE FIRST 					
CORNER JOINT 	SQUARE-GROOVE (BUTT) 						
	SINGLE V-GROOVE 						
	SINGLE U-GROOVE (PARALLEL OR SLOPING SIDES) 						
	SINGLE BEVEL-GROOVE 						
	SINGLE J-GROOVE 						
	SINGLE FLARE-BEVEL GROOVE 						
	CORNER FLANGE 						
	SINGLE FILLET 						

Continued on Next Page

**BASIC TYPES OF JOINTS, WELDS AND WELD SYMBOLS.**  
 TABLE 14-2 (Continued next page.)











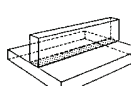
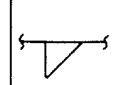
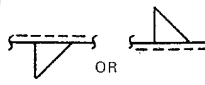

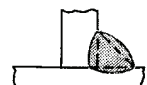
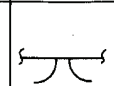
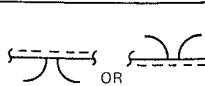

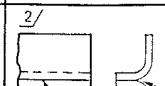
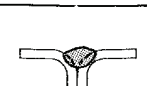
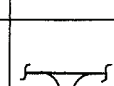
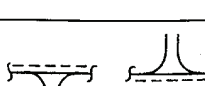
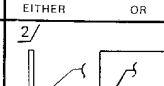
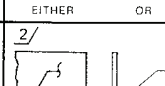

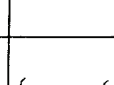
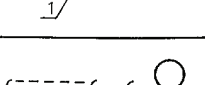
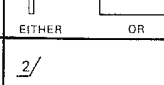
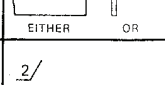
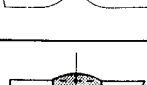
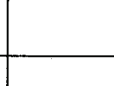
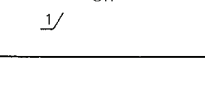



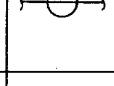
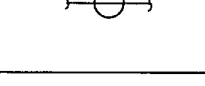

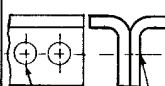

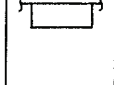
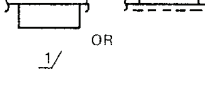
TYPE OF WELD JOINT	TABLE 2 (Continued)		DRAWING REPRESENTATION				DESIRED WELD
	ILLUSTRATION OF APPLICABLE WELDS	SYMBOLIZATION (ARROW [near] SIDE OF JOINT) REFER TO PARA 14.3 & TABLE 1 for 'OTHER SIDE'		POSITION OF ARROW LINE			
		INCH & METRIC (AWS A2.4-2007)	METRIC (ISO 2553-1992)	US	ISO		
Continued	EDGE FLANGE 						
CORNER JOINT 	ARC SPOT WELD 						
	PROJECTION SPOT WELD 						
	PLUG or SLOT SPOT WELD 						
	ARC SEAM WELD 						
	PROJECTION SEAM WELD 						
	TEE-JOINT 	SQUARE GROOVE (ARC SEAM) 					
	SINGLE BEVEL-GROOVE 						
	SINGLE J-GROOVE 						

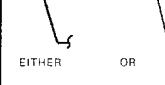
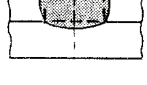
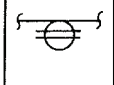
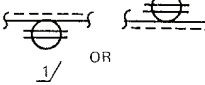
Continued On Next Page

**BASIC TYPES OF JOINTS, WELDS AND WELD SYMBOLS.**  
**TABLE 14-2 (Continued next page.)**

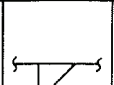
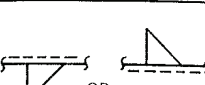
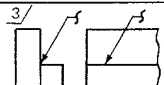
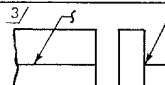
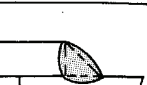

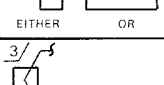
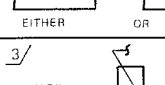
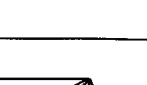
TYPE OF WELD JOINT	TABLE 2 (Continued) DRAWING REPRESENTATION					DESIRED WELD
	ILLUSTRATION OF APPLICABLE WELDS	SYMBOLIZATION (ARROW [near] SIDE OF JOINT) REFER TO PARA 14.3 & TABLE 1 FOR 'OTHER SIDE'		POSITION OF ARROW LINE		
		INCH & METRIC (AWS A2.4-2007)	METRIC (ISO 2553-1992)	US	ISO	
TEE JOINT 	SINGLE FILLET					
	SINGLE FLARE-VEE GROOVE					
	EDGE FLANGE					
	ARC SPOT WELD					
	PROJECTION SPOT WELD					
	PLUG or SLOT SPOT WELD					
	ARC SEAM WELD					
	PROJECTION SEAM WELD					
LAP JOINT 	SINGLE FILLET					
	SINGLE BEVEL-GROOVE					

Continued On Next Page

BASIC TYPES OF JOINTS, WELDS AND WELD SYMBOLS.  
TABLE 14-2 (Continued next page.)



TYPE OF WELD JOINT	TABLE 2 (Continued) DRAWING REPRESENTATION						DESIRED WELD
	ILLUSTRATION OF APPLICABLE WELDS	SYMBOLIZATION (ARROW [near] SIDE OF JOINT) REFER TO PARA 14.3 & TABLE 1 for 'OTHER SIDE'		POSITION OF ARROW LINE			
		INCH & METRIC (AWS A2.4-2007)	METRIC (ISO 2553-1992)	US	ISO		
(Continued)							
LAP JOINT	SINGLE J-GROOVE 						
	PLUG or SLOT SPOT WELD 						
	ARC SPOT WELD 						
	PROJECTION SPOT WELD 						
	ARC SEAM WELD 						
	PROJECTION SEAM WELD 						
EDGE JOINT	SQUARE-GROOVE 						
	SINGLE BEVEL-GROOVE 						
	SINGLE V-GROOVE 						
	SINGLE U-GROOVE 						

Continued On Next Page

BASIC TYPES OF JOINTS, WELDS AND WELD SYMBOLS.  
TABLE 14-2 (Continued next page.)



TYPE OF WELD JOINT	DRAWING REPRESENTATION					DESIRED WELD
	ILLUSTRATION OF APPLICABLE WELDS	SYMBOLIZATION (ARROW [near] SIDE OF JOINT) REFER TO PARA 14.3 & TABLE 1 for 'OTHER SIDE'		POSITION OF ARROW LINE		
		INCH & METRIC (AWS A2.4-2007)	METRIC (ISO 2553-1992)	US	ISO	
Continued	SINGLE J-GROOVE 					
EDGE JOINT 	EDGE FLANGE 					
	CORNER FLANGE 					
	EDGE CORNER FLANGE 					

1/ PREFERRED ON DRAWINGS MADE IN THE U.S. USING METRIC.

2/ THICKNESS RANGE:

INCH	METRIC
.005 thru .060	0.13 thru 1.52

3/ THICKNESS RANGE:

INCH	METRIC
.060 thru .375 AND OVER	1.52 thru 9.52 AND OVER

BASIC TYPES OF JOINTS, WELDS AND WELD SYMBOLS.  
 TABLE 14-2 (Continued from previous page.)



Processes and Variations	Letter Designation	Processes and Variations	Letter Designation
adhesive bonding	AB	projection welding	PW
arc welding	AW	resistance seam welding	RSEW
arc stud welding	SW	high frequency seam welding	RSEW-HF
atomic hydrogen welding	AHW	induction seam welding	RSEW-I
bare metal arc welding	BMAW	resistance spot welding	RSW
carbon arc welding	CAW	upset welding	UW
gas carbon arc welding	CAW-G	high frequency upset welding	UW-HF
shielded carbon arc welding	CAW-S	induction upset welding	UW-I
twin carbon arc welding	CAW-T	soldering	S
electrode gas welding	EGW	dip soldering	DS
flux cored arc welding	FCAW	furnace soldering	FS
gas shielded flux cored arc welding	FCAW-G	induction soldering	IS
self-shielded flux cored arc welding	FCAW-S	infrared soldering	IRS
gas metal arc welding	GMAW	iron soldering	INS
pulsed gas metal arc welding	GMAW-P	resistance soldering	RS
short circuit gas metal arc welding	GMAW-S	torch soldering	TS
gas tungsten arc welding	GTAW	ultrasonic soldering	USS
pulsed gas tungsten arc welding	GTAW-P	wave soldering	WS
plasma arc welding	PAW	solid-state welding	SSW
shielded metal arc welding	SMAW	coextrusion welding	CEW
submerged arc welding	SAW	cold welding	CW
series submerged arc welding	SAW-S	diffusion welding	DFW
brazing	B	explosion welding	EXW
block brazing	BB	forge welding	FW
diffusion brazing	DFB	friction welding	FRW
dip brazing	DB	hot pressure welding	HPW
exothermic brazing	EXB	roll welding	ROW
flow brazing	FLB	ultrasonic welding	USW
furnace brazing	FB	thermal cutting	TC
induction brazing	IB	arc cutting	AC
infrared brazing	IRB	air carbon arc cutting	CAC-A
resistance brazing	RB	carbon arc cutting	CAC
torch brazing	TB	gas metal arc cutting	GMAC
twin carbon arc brazing	TCAB	gas tungsten arc cutting	GTAC
braze welding	BW	plasma arc cutting	PAC
arc braze welding	ABW	shielded metal arc cutting	SMAC
carbon arc braze welding	CABW	electron beam cutting	EBC
exothermic braze welding	EXBW	laser beam cutting	LBC
other welding processes		laser beam air cutting	LBC-A
electron beam welding	EBW	laser beam evaporative cutting	LBC-EV
high vacuum electron beam welding	EBW-HV	laser beam inert gas cutting	LBC-IG
medium vacuum electron beam welding	EBW-MV	laser beam oxygen cutting	LBC-O
nonvacuum electron beam welding	EBW-NV	oxygen cutting	OC
electroslag welding	ESW	flux cutting	FOC
flow welding	FLOW	metal powder cutting	POC
induction welding	IW	oxyfuel gas cutting	OFC
laser beam welding	LBW	oxyacetylene cutting	OFC-A
percussion welding	PEW	oxyhydrogen cutting	OFC-H
thermit welding	TW	oxynatural gas cutting	OFC-N
oxyfuel gas welding	OFW	oxypropane cutting	OFC-P
air acetylene welding	AAW	oxygen arc cutting	AOC
oxyacetylene welding	OAW	oxygen lance cutting	LOC
oxyhydrogen welding	OHW	thermal spraying	THSP
pressure gas welding	PGW	arc spraying	ASP
resistance welding	RW	flame spraying	FLSP
flash welding	FW	plasma spraying	PSP

LETTER DESIGNATIONS OF WELDING AND ALLIED PROCESSES AND THEIR VARIATIONS.  
FIGURE 14-19



Processes and Variations	Letter Designation	Processes and Variations	Letter Designation
adhesive bonding	AB	iron soldering	INS
arc braze welding	ABW	laser beam air cutting	LBC-A
arc cutting	AC	laser beam cutting	LBC
arc spraying	ASP	laser beam evaporative cutting	LBC-EV
arc stud welding	SW	laser beam inert gas cutting	LBC-IG
arc welding	AW	laser beam oxygen cutting	LBC-O
air acetylene welding	AAW	laser beam welding	LBW
air carbon arc cutting	CAC-A	medium vacuum electron beam welding	EBW-MV
atomic hydrogen welding	AHW	metal powder cutting	POC
bare metal arc welding	BMAW	nonvacuum electron beam welding	EBW-NV
block brazing	BB	oxyacetylene cutting	OFC-A
braze welding	BW	oxyacetylene welding	OAW
brazing	B	oxyfuel gas cutting	OFC
carbon arc braze welding	CABW	oxyfuel gas welding	OFW
carbon arc cutting	CAC	oxygen arc cutting	AOC
carbon arc welding	CAW	oxygen cutting	OC
coextrusion welding	CEW	oxygen lance cutting	LOC
cold welding	CW	oxyhydrogen cutting	OFC-H
diffusion brazing	DFB	oxyhydrogen welding	OHW
diffusion welding	DFW	oxynatural gas cutting	OFC-N
dip brazing	DB	oxypropane cutting	OFC-P
dip soldering	DS	percussion welding	PEW
electrogas welding	EGW	plasma arc cutting	PAC
electron beam cutting	EBC	plasma arc welding	PAW
electron beam welding	EBW	plasma spraying	PSP
electroslag welding	ESW	pressure gas welding	PGW
exothermic braze welding	EXBW	projection welding	PW
exothermic brazing	EXB	pulsed gas metal arc welding	GMAW-P
explosion welding	EXW	pulsed gas tungsten arc welding	GTAW-P
flame spraying	FLSP	resistance brazing	RB
flash welding	FW	resistance seam welding	RSEW
flow brazing	FLB	resistance soldering	RS
flow welding	FLOW	resistance spot welding	RSW
flux cored arc welding	FCAW	resistance welding	RW
flux cutting	FOC	roll welding	ROW
forge welding	FOW	self shielded flux cored arc welding	FCAW-S
friction welding	FRW	series submerged arc welding	SAW-S
furnace brazing	FB	shielded carbon arc welding	CAW-S
furnace soldering	FS	shielded metal arc cutting	SMAC
gas carbon arc welding	CAW-G	shielded metal arc welding	SMAW
gas metal arc cutting	GMAC	short circuit gas metal arc welding	GMAW-S
gas metal arc welding	GMAW	soldering	S
gas shielded flux cored arc welding	FCAW-G	solid-state welding	SSW
gas tungsten arc cutting	GTAC	submerged arc welding	SAW
gas tungsten arc welding	GTAW	thermal cutting	TC
high frequency seam welding	RSEW-HF	thermal spraying	THSP
high frequency upset welding	UW-HF	thermit welding	TW
high vacuum electron beam welding	EBW-HV	torch brazing	TB
hot pressure welding	HPW	torch soldering	TS
induction brazing	IB	twin carbon arc brazing	TCAB
induction seam welding	RSEW-I	twin carbon arc welding	CAW-T
induction soldering	IS	ultrasonic soldering	USS
induction upset welding	UW-I	ultrasonic welding	USW
induction welding	IW	upset welding	UW
infrared brazing	IRB	wave soldering	WS
infrared soldering	IRS		

ALPHABETICAL CROSS REFERENCE TO FIGURE 14-19 BY LETTER DESIGNATION.  
FIGURE 14-20

**MASTER CHART OF WELDING AND ALLIED PROCESSES**

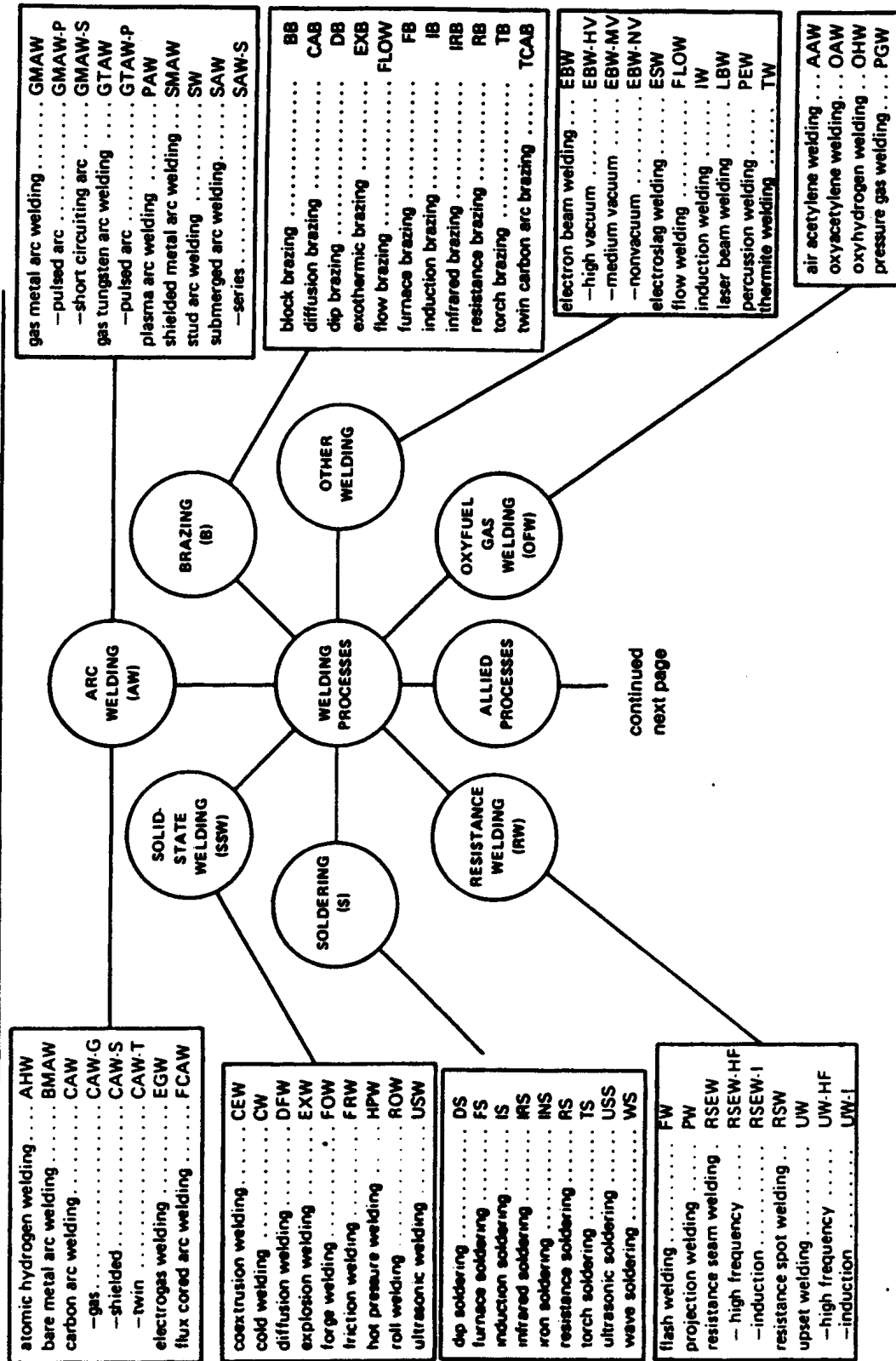

MASTER CHART OF WELDING AND ALLIED PROCESSES.  
FIGURE 14-21 (Continued on next page.)



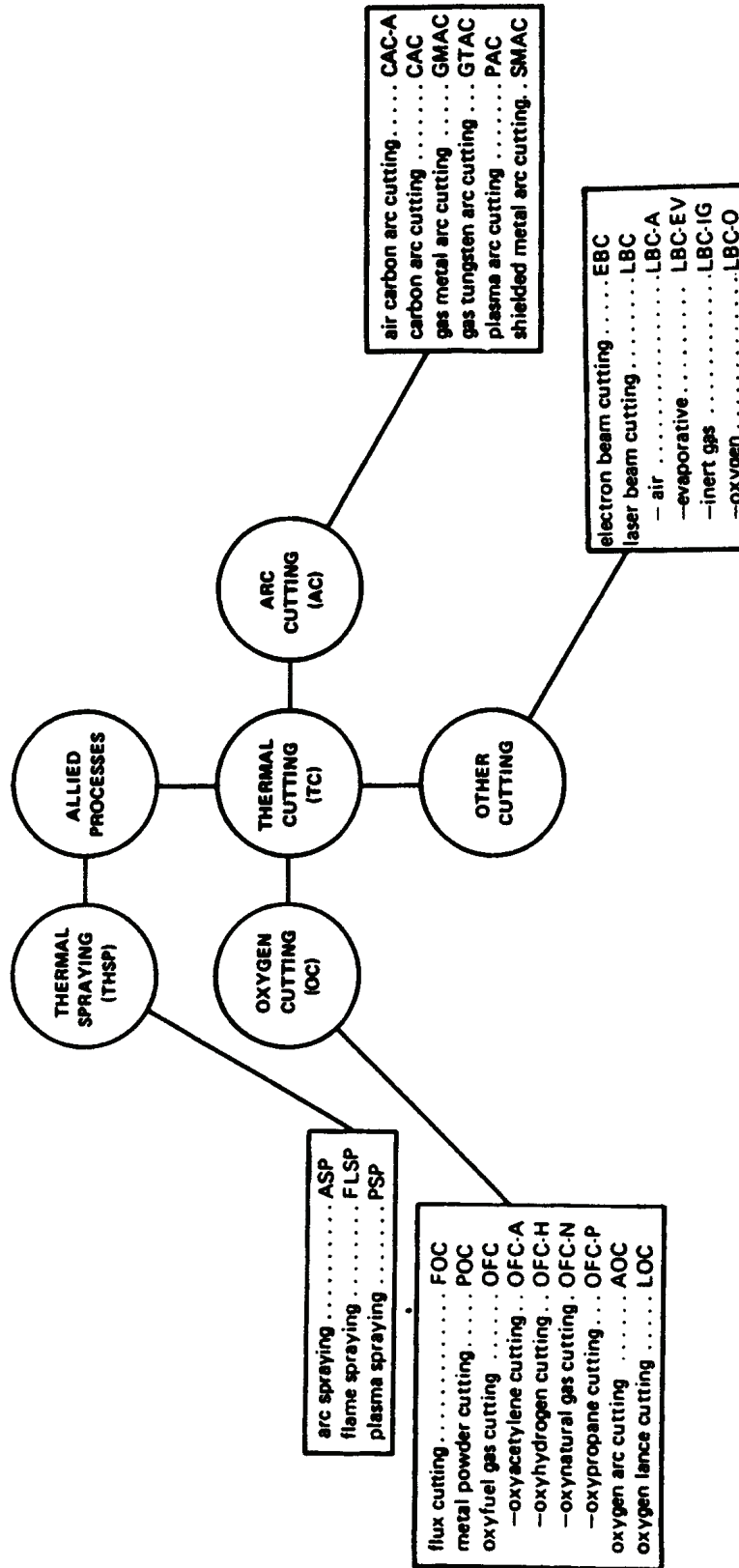

MASTER CHART OF WELDING AND ALLIED PROCESSES.  
FIGURE 14-21 (Continued from Previous Page)



**NOTES:**